

powermax800[®]

Plasma Arc Cutting System

***Service Manual
802280 - Revision 4***

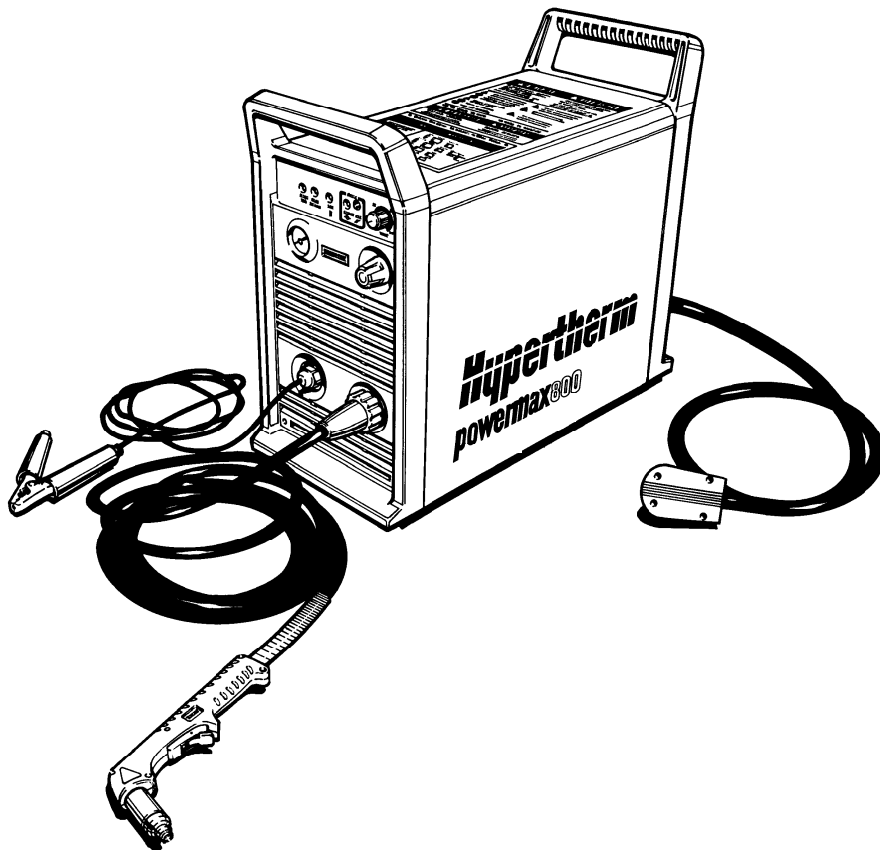

EN50199
EN50192

powermax800

Plasma Arc Cutting System

Service Manual IM-228 (P/N 802280)

**for systems beginning with serial number
800-010000**

Revision 4 December, 1997

**Hypertherm, Inc.
P.O. Box 5010
Hanover, New Hampshire 03755-5010
Tel.: (603) 643-3441
Fax: (603) 643-5352**

**© Copyright 1997 Hypertherm, Inc.
All Rights Reserved**

**HYPERTHERM and POWERMAX are trademarks of Hypertherm, Inc. and may be
registered in the United States and/or other countries**

Hypertherm Offices Worldwide:

Hypertherm, Inc.

Etna Road, P.O. Box 5010
Hanover, NH 03755 USA
Tel.: (603) 643-3441 (Main Office)
Fax: (603) 643-5352 (All Departments)
Tel.: (800) 643-9878 (Technical Service)
Tel.: (800) 737-2978 (Customer Service)

Hypertherm Plasmatechnik GmbH

Ohmstrasse 6
D-63477 Maintal, Germany
Tel.: 49 6181 94070
Fax: 49 6181 940719

European Technical Support Organization (ETSO)

Ohmstrasse 6
D-63477 Maintal, Germany
Tel.: 49 6181 94070
Fax: 49 6181 940739

Hypertherm Singapore Pte Ltd

No. 19 Kaki Bukit Road 2
K.B. Warehouse Complex
Singapore 417847, Republic of Singapore
Tel.: 65 841 2489
Fax: 65 841 2490

Hypertherm U.K.

9 Berkeley Court • Manor Park
Runcorn, Cheshire, England WA7 1TQ
Tel.: 44 1928 579 074
Fax: 44 1928 579 604

Hypertherm France

10, Allée de l'Isara
F-95000 Cergy-Pontoise, France
Tel.: 33 1 34 24 03 05
Fax: 33 1 34 25 09 64

Hypertherm Italy

Via Stilicone 18
20154 Milan, Italy
Tel.: 39 2 34 53 22 11
Fax: 39 2 34 53 20 18

EMC INTRODUCTION

The 400V CE power supply has been built in compliance with standard EN50199. To ensure that the equipment works in a compatible manner with other radio and electronic systems, the equipment should be installed and used in accordance with the information below to achieve electromagnetic compatibility.

The limits required by EN50199 may not be adequate to completely eliminate interference when the affected equipment is in close proximity or has a high degree of sensitivity. In such cases it may be necessary to use other measures to further reduce interference.

This plasma equipment should be used only in an industrial environment. It may be difficult to ensure electromagnetic compatibility in a domestic environment.

INSTALLATION AND USE

The user is responsible for installing and using the plasma equipment according to the manufacturer's instructions. If electromagnetic disturbances are detected then it shall be the responsibility of the user to resolve the situation with the technical assistance of the manufacturer. In some cases this remedial action may be as simple as earthing the cutting circuit, see *Earthing of Workpiece*. In other cases it could involve constructing an electromagnetic screen enclosing the power source and the work complete with associated input filters. In all cases electromagnetic disturbances must be reduced to the point where they are no longer troublesome.

ASSESSMENT OF AREA

Before installing the equipment the user shall make an assessment of potential electromagnetic problems in the surrounding area. The following shall be taken into account:

- a. Other supply cables, control cables, signalling and telephone cables; above, below and adjacent to the cutting equipment.
- b. Radio and television transmitters and receivers.
- c. Computer and other control equipment.
- d. Safety critical equipment, for example guarding of industrial equipment.
- e. Health of the people around, for example the use of pacemakers and hearing aids.

f. Equipment used for calibration or measurement.

g. Immunity of other equipment in the environment. User shall ensure that other equipment being used in the environment is compatible. This may require additional protection measures.

h. Time of day that cutting or other activities are to be carried out.

The size of the surrounding area to be considered will depend on the structure of the building and other activities that are taking place. The surrounding area may extend beyond the boundaries of the premises.

METHODS OF REDUCING EMISSIONS

Mains Supply

Cutting equipment should be connected to the mains supply according to the manufacturer's recommendations. If interference occurs, it may be necessary to take additional precautions such as filtering of the mains supply. Consideration should be given to shielding the supply cable of permanently installed cutting equipment, in metallic conduit or equivalent. Shielding should be electrically continuous throughout its length. The shielding should be connected to the cutting mains supply so that good electrical contact is maintained between the conduit and the cutting power source enclosure

Maintenance of Cutting Equipment

The cutting equipment should be routinely maintained according to the manufacturer's recommendations. All access and service doors and covers should be closed and properly fastened when the cutting equipment is in operation. The cutting equipment should not be modified in any way except for those changes and adjustments covered in the manufacturer's instructions. In particular, the spark gaps of arc striking and stabilizing devices should be adjusted and maintained according to the manufacturer's recommendations.

Cutting Cables

The cutting cables should be kept as short as possible and should be positioned close together, running at or close to the floor level.

Equipotential Bonding

Bonding of all metallic components in the cutting installation and adjacent to it should be considered. However, metallic components bonded to the workpiece will increase the risk that the operator could receive a shock by touching these metallic components and the electrode at the same time. The operator should be insulated from all such bonded metallic components.

Earthing of Workpiece

Where the workpiece is not bonded to earth for electrical safety, nor connected to earth because of its size and position, for example, ship's hull or building steelwork, a connection bonding the workpiece to earth may reduce emissions in some, but not all instances. Care should be taken to prevent the earthing of the workpiece increasing the risk of injury to users, or damage to other electrical equipment. Where necessary, the connection of the workpiece to earth should be made by a direct connection to the workpiece, but in some countries where direct connection is not permitted, the bonding should be achieved by suitable capacitances selected according to national regulations.

Note. The cutting circuit may or may not be earthed for safety reasons. Changing the earthing arrangements should only be authorized by a person who is competent to assess whether the changes will increase the risk of injury, for example, by allowing parallel cutting current return paths which may damage the earth circuits of other equipment. Further guidance is given in IEC TC26 (sec)94 and IEC TC26/108A/CD Arc Welding Equipment Installation and Use.

Screening and Shielding

Selective screening and shielding of other cables and equipment in the surrounding area may alleviate problems of interference. Screening of the entire plasma cutting installation may be considered for special applications.

WARRANTY



WARNING



Genuine Hypertherm parts are the factory-recommended replacement parts for your Hypertherm system. Any damage caused by the use of other than genuine Hypertherm parts may not be covered by the Hypertherm warranty.

GENERAL

HYPERTHERM, Inc. warrants that Products shall be free from defects in materials and workmanship, under proper and normal use for which such Equipment is recommended, for a period of two (2) years, except only with respect to the Torch, for which the warranty period shall be one (1) year, from the date of its delivery to you.

HYPERTHERM, at its sole option, shall repair, replace, or adjust, free of charge, any Products covered by this warranty which shall be returned with HYPERTHERM's prior authorization (which shall not be unreasonably withheld), properly packed, to HYPERTHERM's place of business in Hanover, New Hampshire, all costs, insurance and freight prepaid, and which examination proves not to be free from defects in materials and workmanship. HYPERTHERM shall not be liable for any repairs, replacements, or adjustments of Products covered by this warranty, except those made pursuant to this paragraph or with HYPERTHERM's written consent. This warranty shall not apply to any Product which has been mishandled, incorrectly installed, modified or assembled by you or any other person. HYPERTHERM shall be liable for breach of this warranty only if it receives written notice of such breach within the applicable warranty period specified herein above. THE FOREGOING SHALL CONSTITUTE THE SOLE REMEDY TO DISTRIBUTORS OR THEIR CUSTOMERS FOR ANY BREACH BY HYPERTHERM OF ITS WARRANTY.

PATENT INDEMNITY

Except only in cases of Products not manufactured by HYPERTHERM or manufactured by a person other than HYPERTHERM not in strict conformity with HYPERTHERM's specifications, and in cases of designs, processes, formulae or combinations not developed or purported to be developed by HYPERTHERM, HYPERTHERM agrees to indemnify, protect and hold harmless Distributors and their customers against any and all liability or claims in any manner imposed upon or accruing against Distributors and their customers because of the use in or about the construction or operation of Equipment or any design, system, formula, combination, article or material which infringes or alleges to infringe on any patent or other right. Distributors shall notify HYPERTHERM promptly upon learning of any action or threatened action in connection with any such alleged infringement, and each party may appoint its own counsel for any such action or threatened action.

DISCLAIMER OF OTHER WARRANTIES

HYPERTHERM MAKES NO WARRANTIES REGARDING PRODUCTS MANUFACTURED BY IT OR OTHERS (INCLUDING WITHOUT IMPLIED LIMITATION WARRANTIES AS TO MERCHANTABILITY OR FITNESS FOR A PARTICULAR PURPOSE), EITHER EXPRESS OR IMPLIED, EXCEPT AS PROVIDED HEREIN. This warranty is in lieu of any and all warranties, express or implied, by law or otherwise; and Distributors are not authorized to give any other warranty purporting to be binding upon HYPERTHERM upon resale of Products to their customers. IN NO EVENT shall HYPERTHERM be liable for incidental or consequential damages or injury to the person or property of anyone by reason of any defect in any Equipment sold hereunder.

TABLE OF CONTENTS

SECTION 1 SAFETY	1-1
About Notes, Cautions & Warnings	1-2
Safety Instructions	1-2
Eye Protection	1-2
Skin Protection	1-2
Toxic Fume Prevention	1-2
Fire Prevention	1-2
Electric Shock Prevention	1-2
Explosion Prevention	1-3
Noise Prevention	1-4
Grounding	1-4
Safety Reminders	1-4
Electronic Health Support Equipment	1-4
SECTION 1A SÉCURITÉ	1a-1
Au sujet des Notes, Attention et avertissement	1a-1
Consignes de sécurité	1a-2
Protection des yeux	1a-2
Protection de la peau	1a-2
Prévention des vapeurs toxiques	1a-2
Prévention des incendies	1a-2
Prévention des chocs électriques	1a-2
Prévention des explosions	1a-3
Protection contre le bruit	1a-4
Mise à la masse et à la terre	1a-4
Rappels de sécurité	1a-4
Prothèses électroniques	1a-4
SECTION 2 DESCRIPTION & SPECIFICATIONS	2-1
Introduction	2-2
Specifications	2-3
PAC121 50A Torches	2-4
IEC Symbols Used	2-6
SECTION 3 MAINTENANCE	3-1
Introduction	3-2
Routine Maintenance	3-2
Theory of Operation	3-4
Sequence of Operation	3-6
Troubleshooting	3-7
Power Board	3-26
Control Board	3-28
Torch Check	3-30
PAC121TS Torch Parts Removal and Replacement	3-32
PAC121MS Torch Parts Removal and Replacement	3-34
Quick Disconnect O-Ring Removal and Replacement	3-36
SECTION 4 PARTS LIST	4-1
Power Supply - 208/240/480V	4-2
200/230/400V	4-2
PAC121TS Torch Assembly	4-10
PAC121MS Torch Assembly	4-11
Consumable Parts	4-12
Powermax800 Field Upgrade Kits and Optional Parts	4-13
Power Supplies - 208/240/480V	4-13
Power Supplies - 200/230/400V	4-13
Recommended Spare Parts - Powermax800 - 208/240/480V	4-14
Recommended Spare Parts - Powermax800 - 200/230/400V	4-14

TABLE OF CONTENTS

SECTION 5 PARTS LIST - CE	5-1
Power Supply - 400V CE	5-2
PAC121TS Torch Assembly	5-10
PAC121MS Torch Assembly	5-11
Consumable Parts - CE	5-12
Powermax800 Field Upgrade Kits and Optional Parts	5-13
Power Supplies - 400V CE	5-13
Recommended Spare Parts - Powermax800 - 400V CE	5-14

SECTION 6 WIRING DIAGRAMS	6-1
Powermax800 Electrical Schematic: 208/240/480V	6-2
Powermax800 Electrical Schematic: 200/230/400V	6-3
Powermax800 Electrical Schematic: 400V CE	6-4
Powermax800 Troubleshooting Schematic 1 of 2	6-5
Powermax800 Troubleshooting Schematic 2 of 2	6-6
Powermax800 CE Troubleshooting Schematic 1 of 2	6-7
Powermax800 CE Troubleshooting Schematic 2 of 2	6-8

APPENDIX A AERATION MANIFOLD FOR CUTTING ALUMINUM	a-1
--	-----

APPENDIX B STANDARDS INDEX	a-2
---	-----

ILLUSTRATIONS

Figure 2-1 Powermax800 Hand Plasma Cutting System	2-2
Figure 2-2 Powermax800 Power Supply with Dimensions	2-3
Figure 2-3 PAC121TS Torch with Dimensions	2-4
Figure 2-4 PAC121MS Torch with Dimensions	2-4
Figure 2-5  Mark Label	2-5
Figure 3-1 Filter Assembly	3-2
Figure 3-2 Air Filter Removal	3-3
Figure 3-3 Inverter Links	3-4
Figure 3-4 Single-Phase, 240 or 208V Block Diagram	3-5
Figure 3-5 Back Side of Power Board - Test Points	3-27
Figure 3-6 Control Board Test Points	3-29
Figure 3-7 PAC121TS Torch Main Body Removal	3-32
Figure 3-8 PAC121TS Torch Switch Removal	3-33
Figure 3-9 PAC121MS Torch Assembly	3-35
Figure 3-10 Quick Disconnect O-Ring Removal and Replacement	3-36
Figure 4-1 Powermax800 - Front	4-3
Figure 4-2 Powermax800 - Top and Right Side	4-5
Figure 4-3 Powermax800 - Bottom and Left Side	4-7
Figure 4-4 Powermax800 - Rear	4-9
Figure 4-5 PAC121TS Torch Assembly and Leads	4-10
Figure 4-6 PAC121MS Torch Assembly and Leads	4-11
Figure 4-7 Consumable Parts	4-12
Figure 5-1 Powermax800 CE - Front	5-3
Figure 5-2 Powermax800 CE - Top and Right Side	5-5
Figure 5-3 Powermax800 CE - Bottom and Left Side	5-7
Figure 5-4 Powermax800 CE - Rear	5-9
Figure 5-5 PAC121TS Torch Assembly and Leads	5-10
Figure 5-6 PAC121MS Torch Assembly and Leads	5-11
Figure 5-7 Consumable Parts - CE	5-12
Figure a-1 Aeration Manifold	a-1

Section 1 SAFETY

In this section:

About Notes< Cautions and Warnings	1-1	Pressure Regulators	1-3
Safety Instructions	1-2	Hoses	1-3
Eye Protection	1-2	Noise Protection	1-4
Skin Protection	1-2	Grounding	1-4
Toxic Fume Prevention	1-2	Input Power	1-4
Fire Prevention	1-2	Work Cable	1-4
Electric Shock Prevention	1-2	Work Table	1-4
Explosion Prevention	1-3	Safety Reminders	1-4
Compressed Gas Cylinders	1-3	Electronic Health Support Equipment	1-4

Before using this plasma arc system. . . .

Each person who will operate this equipment, perform service or maintenance, or supervise its use must read the safety instructions and warnings in this manual and the labels on the equipment.

About Notes, Cautions and Warnings

Notes: Throughout this manual, useful information for operating the plasma system is presented in “notes”, such as shown in this paragraph.

Cautions: Information in bold type and surrounded by a box describes a situation that may cause damage to the plasma system.



WARNINGS



Warnings describe situations that present a physical danger to the operator, and advice to avoid or correct the situation. Each type of warning includes applicable danger symbols, such as a hand burn, electrical shock, fire, explosion, etc.



WARNING — Instant-On Torches

Instant-on torches produce a plasma arc immediately after the torch switch is pushed.

Always hold a hand torch away from your body as a precaution against accidental torch firing. Be aware of this hazard, which has potential for serious bodily injury.





WARNING — Electric Shock

- Never touch the torch body, workpiece or the water in a water table when operating the plasma system.
- When using a water table, be sure that it is correctly connected to earth ground.
- Operating the plasma system completes an electrical circuit between the torch and the workpiece and anything touching the workpiece. The workpiece is part of the electrical circuit.

SAFETY

Eye Protection

- Wear dark safety glasses or goggles with side shields, or a welding helmet, in accordance with applicable national or local codes, to protect eyes against the plasma arc's ultraviolet and infrared rays.

Arc Current		Lens Shade	
		AWS (USA)	ISO-4850
Up to 100 A		No. 8	No. 11
100–200 A		No. 10	No. 11-12
200–400 A		No. 12	No. 13
Over 400 A		No. 14	No. 14

- Replace the glasses, goggles or helmet when the lens becomes pitted or broken.
- Warn other people in the area not to look directly at the arc unless they are wearing glasses, goggles or a helmet.
- Prepare the cutting area in a manner that reduces the reflection and transmission of ultraviolet light:
 - Paint walls and other surfaces with dark colors to reduce reflection.
 - Install protective screens or curtains to reduce ultraviolet transmission.

Skin Protection

- Wear protective clothing to protect against burns caused by ultraviolet light, sparks and hot metal:
 - Gauntlet gloves, safety shoes and hat.
 - Flame-retardant clothing which covers all exposed areas.
 - Cuffless trousers to prevent entry of sparks and slag.

Toxic Fume Prevention

- Keep the cutting area well ventilated.
- Remove all chlorinated solvents from the cutting area before cutting. Certain chlorinated solvents decompose when exposed to ultraviolet radiation to form phosgene gas.
- Wear proper breathing mask and use proper ventilation when cutting galvanized metal.
- Do not cut containers with toxic materials inside. Clean containers that have held toxic materials thoroughly before cutting.



WARNING — Toxic Fumes

Do not cut metal or painted metals containing zinc, lead, cadmium or beryllium unless the operator, or anyone else subjected to the fumes, wears respiratory equipment or an air-supplied helmet.



Fire Prevention



- Make fire extinguishers available in the cutting area.
- Remove all combustible materials from the immediate cutting area to a distance of at least 35 feet (10 m).
- Quench freshly cut metal or allow metal to cool before handling it or bringing it into contact with combustible materials.
- Never use a plasma system to cut containers with potentially flammable materials inside. Such containers must be thoroughly cleaned prior to cutting.
- Ventilate potentially flammable atmospheres before cutting with a plasma system. When cutting with oxygen as the plasma gas, an exhaust ventilation system is required.
- Never operate the plasma system in an atmosphere which contains heavy concentrations of dust, flammable gas or combustible liquid vapors unless properly vented.

Electric Shock Prevention



All Hypertherm plasma systems use high voltage (up to 280 VDC) to initiate the plasma arc. Take the following precautions when operating the plasma system:

- Wear insulated gloves and boots, and keep body and clothing dry.
- Do not stand, sit or lie on—or touch—any wet surface when using the plasma system.
- Maintain proper insulation against electrical shock. If you must work in or near a damp area, use extreme caution.
- Provide a wall-mounted disconnect switch with properly sized fuses close to the power supply. This switch allows the operator to turn the power supply off quickly in an emergency situation.
- Conform to all local electrical codes for primary wiring sizes and types.
- Inspect the primary power cord frequently for damage or cracking of the cover. Bare wiring can kill. Do not use a system with a damaged power cord. Replace a damaged power cord immediately.
- Inspect the torch leads. Replace if frayed or damaged.
- Do not pick up the workpiece, including the waste cutoff, while you cut. Leave the workpiece in place or on the workbench with the work cable attached during the cutting process.

Electric Shock Prevention (continued)

- Before changing the torch parts, disconnect the main power or unplug the power supply. After changing torch parts and replacing the retaining cap, plug in the power supply again.
- Never bypass or shortcut the safety interlocks.
- Before removing a power supply cover for maintenance, disconnect the main power at the wall disconnect switch or unplug the power supply. To avoid exposure to severe electrical hazard, wait five minutes after disconnecting the main power to allow capacitors to discharge.
- Never operate the plasma system unless the power supply unit covers are in place. Exposed power supply connections present a severe electrical hazard.

Explosion Prevention



WARNING — Compressed Gas

The plasma system uses compressed gas. Observe proper precautions when handling and using compressed gas equipment and cylinders.

- Do not use the plasma system if explosive dust or vapors may be present.
- Do not cut pressurized cylinders or any closed container.



WARNING — Hydrogen Explosion Hazard

If your system uses hydrogen, remember that this is a flammable gas that presents an explosion hazard. Keep flames away from cylinders containing hydrogen mixtures and hoses that carry hydrogen mixtures. Also, keep flames and sparks away from the torch when using argon-hydrogen as the plasma gas.

Compressed Gas Cylinders

Handle and use compressed gas cylinders in accordance with safety standards published by the U.S. Compressed Gas Association (CGA), American Welding Society (AWS), Canadian Standards Association (CSA) or applicable national or local codes.

- Never use a cylinder that leaks or is physically damaged.

- Never use a cylinder that is not upright and secured in place.
- Never move or transport a cylinder without its protective valve cover in place.
- Never use a gas cylinder or its contents for any purpose other than that for which it is intended.
- Never lubricate cylinder valves with oil or grease.
- Never allow electrical contact between the plasma arc and a cylinder.
- Never expose cylinders to excessive heat, sparks, slag or open flame.
- Never use hammers, wrenches or other tools to open stuck cylinder valves.

Pressure Regulators

- Be certain that all pressure regulators are in proper working condition.
- Never use a regulator for any gas other than that for which it is intended.
- Never use a regulator that leaks, creeps excessively or is physically damaged in any way.
- Never attempt to lubricate a regulator with oil or grease.



WARNING — Hydrogen Detonation with Aluminum Cutting

When cutting aluminum underwater, or with the water touching the underside of the aluminum, free hydrogen gas may collect under the workpiece and detonate during plasma cutting operations.

Installing an aeration manifold on the floor of the water table is an effective way to eliminate the possibility of hydrogen detonation when cutting aluminum. Refer to the Appendix section of this manual for instructions on how to fabricate an aeration manifold.

Hoses

- Label and color-code all gas hoses in order to clearly identify the type of gas in each hose. Consult applicable national or local codes.
- Never use the oxygen hose for any gas other than oxygen.
- Examine hoses at regular intervals for leaks, wear, loose connections or other hazard.
- Replace hose that is damaged in any way.

Hoses (continued)

- Keep hose lengths to a minimum to prevent damage, reduce pressure drop and to prevent possible flow restrictions.
- Prevent kinking by laying out hoses as straight as possible between termination points.
- Coil any excess hose and place it out of the way to prevent damage and to eliminate the danger of tripping.

Noise Protection



The plasma cutting process can generate high levels of noise. Depending on the arc current, material being cut, acoustics and size of the cutting room, distance from the torch and other factors, acceptable noise levels as defined by national or local codes may be exceeded by your plasma system.

- Always wear proper ear protection when cutting or gouging with the plasma system.

Grounding

Input Power

- Be sure to connect the power cord ground wire to the ground in the disconnect box.
- If installation of the plasma system involves connecting the power cord to the power supply, be sure to properly connect the power cord ground wire. Conform to Canadian Standards Association (CSA) standards by placing the power cord ground wire on the stud first; then place any other ground wires on top of the power cord ground. Fasten the retaining nut tightly.
- Tighten all electrical connections to avoid excessive heating.

Work Cable

- Attach the work cable securely to the workpiece or the work table by making good metal-to-metal contact. Do not connect it to the piece that will fall away when the cut is complete.

Work Table

- Connect the work table to a high-quality earth ground, in accordance with the U.S. National Electrical Code, Article 250, Section H, Grounding Electrode System, or other appropriate national or local codes.

Safety Reminders

- Never bypass or shortcut the safety interlocks on any of the plasma system units.
- Except in Hypertherm's largest mechanized systems, all Hypertherm torches are designed with a safety interlock that prevents firing of the plasma arc when the retaining cap is loosened.
- Each Hypertherm plasma system is designed to be used only with specific Hypertherm torches. Do not substitute other torches which could overheat and present a potentially dangerous situation to the operator and any personnel in the area. Hypertherm's warranty does not cover problems caused by the use of torches not made by Hypertherm.
- Use only consumable parts and replacement parts made by Hypertherm. Hypertherm's warranty does not cover problems caused by the use of parts not made by Hypertherm.
- Never operate the plasma system with any of its covers not in place. This would be hazardous to the operator and other people in the area, and prevents the proper cooling of the equipment.

Electronic Health Support Equipment

Plasma arc cutting and gouging systems create electric and magnetic fields that may interfere with the correct operation of electronic health support equipment, such as pacemakers or hearing aids. Any person who wears a pacemaker or hearing aid should consult a doctor before operating or being near any plasma system when it is in use. To minimize exposure to EMF:

- Keep both the work cable and the torch lead on one side of your body. Keep your body from coming in between the torch lead and the work cable.
- Route torch leads as close as possible to work cable.
- Do not wrap the torch lead or work cable around your body.
- Stay as far away from the power supply as possible.

Section 1a SÉCURITÉ



IDENTIFIER LES CONSIGNES DE SÉCURITÉ

Les symboles indiqués dans cette section sont utilisés pour identifier les risques éventuels. Si vous trouvez un symbole de sécurité, que ce soit dans ce manuel ou sur l'équipement, soyez conscient des risques de blessures et suivez les instructions correspondantes afin d'éviter ces risques.



SUIVRE LES INSTRUCTIONS DE SÉCURITÉ

Lire attentivement toutes les consignes de sécurité dans le présent manuel et sur les étiquettes de sécurité se trouvant sur la machine.

- Les étiquettes de sécurité doivent rester lisibles. Remplacer immédiatement les étiquettes manquantes ou abîmées.
- Apprendre à faire fonctionner la machine et à utiliser correctement les commandes. Ne laisser personne utiliser la machine sans connaître son fonctionnement.

- Garder la machine en bon état. Des modifications non autorisées sur la machine peuvent engendrer des problèmes de sécurité et raccourcir la durée d'utilisation de l'équipement.

DANGER AVERTISSEMENT PRÉCAUTION

Les signaux DANGER ou AVERTISSEMENT sont utilisés avec un symbole de sécurité, DANGER correspondant aux risques les plus sérieux.

- Les étiquettes de sécurité DANGER et AVERTISSEMENT sont situées sur la machine pour signaler certains dangers spécifiques.
- Les messages d'AVERTISSEMENT précèdent les instructions d'utilisation expliquées dans ce manuel et signalent les risques de blessures ou de mort au cas où ces instructions ne seraient pas suivies correctement.
- Les messages de PRÉCAUTION précèdent les instructions d'utilisation contenues dans ce manuel et signalent que le matériel risque d'être endommagé si les instructions ne sont pas suivies correctement.



LE COUPAGE PEUT PROVOQUER UN INCENDIE OU UNE EXPLOSION

Prévention des incendies

- Avant de commencer, s'assurer que la zone de coupage ne présente aucun danger. Conserver un extincteur à proximité.
- Éloigner toute matière inflammable à une distance d'au moins 10 m du poste de coupage.
- Tremper le métal chaud ou le laisser refroidir avant de le manipuler ou avant de le mettre en contact avec des matériaux combustibles.
- Ne jamais couper des récipients pouvant contenir des matières inflammables avant de les avoir vidés et nettoyés correctement.
- Aérer toute atmosphère potentiellement inflammable avant d'utiliser un système plasma.
- Lors de l'utilisation d'oxygène comme gaz plasma, un système de ventilation par aspiration est nécessaire.

Prévention des explosions

- Ne pas couper en présence de poussière ou de vapeurs.
- Ne pas couper de bouteilles, de tuyaux ou autres récipients fermés et pressurisés.
- Ne pas couper de récipients contenant des matières combustibles.



AVERTISSEMENT

Risque d'explosion
Argon-hydrogène et méthane

L'hydrogène et le méthane sont des gaz inflammables et potentiellement explosifs. Conserver à l'écart de toute flamme les bouteilles et tuyaux contenant des mélanges à base d'hydrogène ou de méthane. Maintenir toute flamme et étincelle à l'écart de la torche lors de l'utilisation d'un plasma d'argon-hydrogène ou de méthane.



AVERTISSEMENT

Détonation de l'hydrogène lors du
coupage de l'aluminium

- Lors du coupage de l'aluminium sous l'eau, ou si l'eau touche la partie inférieure de la pièce d'aluminium, de l'hydrogène libre peut s'accumuler sous la pièce à couper et détonner lors du coupage plasma.
- Installer un collecteur d'aération au fond de la table à eau afin d'éliminer les risques de détonation de l'hydrogène. Se référer à l'annexe du manuel pour plus de renseignements sur les collecteurs d'aération.



LES CHOCs ÉLECTRIQUES PEUVENT ÊTRE FATALS

Toucher une pièce électrique sous tension peut provoquer un choc électrique fatal ou des brûlures graves.

- La mise en fonctionnement du système plasma ferme un circuit électrique entre la torche et la pièce à couper. La pièce à couper et tout autre élément en contact avec cette pièce font partie du circuit électrique.
- Ne jamais toucher le corps de la torche, la pièce à couper ou l'eau de la table à eau pendant le fonctionnement du système plasma.

Prévention des chocs électriques

Tous les systèmes plasma Hypertherm utilisent des hautes tensions pour le coupage (souvent de 200 à 400 V). On doit prendre les précautions suivantes quand on utilise le système plasma :

- Porter des bottes et des gants isolants et garder le corps et les vêtements au sec.
- Ne pas se tenir, s'asseoir ou se coucher sur une surface mouillée, ni la toucher quand on utilise le système plasma.
- S'isoler de la surface de travail et du sol en utilisant des tapis isolants secs ou des couvertures assez grandes pour éviter tout contact physique avec le travail ou le sol. S'il s'avère nécessaire de travailler dans ou près d'un endroit humide, procéder avec une extrême prudence.
- Installer un sectionneur avec fusibles appropriés, à proximité de la source de courant. Ce dispositif permet à l'opérateur d'arrêter rapidement la source de courant en cas d'urgence.
- En cas d'utilisation d'une table à eau, s'assurer que cette dernière est correctement mise à la terre.

- Installer et mettre à la terre l'équipement selon les instructions du présent manuel et conformément aux codes électriques locaux et nationaux.
- Inspecter fréquemment le cordon d'alimentation primaire pour s'assurer qu'il n'est ni endommagé, ni fendu. Remplacer immédiatement un cordon endommagé. **Un câble dénudé peut tuer.**
- Inspecter et remplacer les câbles de la torche qui sont usés ou endommagés.
- Ne pas saisir la pièce à couper ni les chutes lors du coupage. Laisser la pièce à couper en place ou sur la table de travail, le câble de retour connecté lors du coupage.
- Avant de vérifier, de nettoyer ou de remplacer les pièces de la torche, couper l'alimentation ou débrancher la prise de courant.
- Ne jamais contourner ou court-circuiter les verrouillages de sécurité.
- Avant d'enlever le capot du système ou de la source de courant, couper l'alimentation électrique. Attendre ensuite 5 minutes pour que les condensateurs se déchargent.
- Ne jamais faire fonctionner le système plasma sans que les capots de la source de courant ne soient en place. Les raccords exposés de la source de courant sont extrêmement dangereux.
- Lors de l'installation des connexions, attacher tout d'abord la prise de terre appropriée.
- Chaque système plasma Hypertherm est conçu pour être utilisé uniquement avec des torches Hypertherm spécifiques. Ne pas utiliser des torches inappropriées qui pourraient surchauffer et présenter des risques pour la sécurité.



LE COUPAGE PEUT PRODUIRE DES VAPEURS TOXIQUES

Le coupage peut produire des vapeurs et des gaz toxiques qui réduisent le niveau d'oxygène dans l'air et peuvent provoquer des blessures, voire la mort.

- Conserver le poste de coupage bien aéré ou utiliser un masque respiratoire homologué.
- Ne pas procéder au coupage près d'endroits où s'effectuent le dégraissage, le nettoyage ou la vaporisation. Certains solvants chlorés se décomposent sous l'effet des rayons ultraviolets et forment du phosgène.
- Ne pas couper des métaux peints ou contenant des matières toxiques comme le zinc (galvanisé), le plomb, le cadmium ou le béryllium, à moins que la zone de travail soit très bien ventilée et que l'opérateur porte un masque respiratoire. Les revêtements et métaux contenant ces matières peuvent produire des vapeurs toxiques lors du coupage.
- Ne jamais couper de récipients pouvant contenir des matières inflammables avant de les avoir vidés et nettoyés correctement.

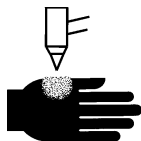

L'ARC PLASMA PEUT PROVOQUER DES BLESSURES OU DES BRÛLURES

Torches à allumage instantané

L'arc plasma s'allume immédiatement après que la torche soit mise en marche.

L'arc plasma coupe facilement les gants et la peau.

- Rester éloigné de l'extrémité de la torche.
- Ne pas tenir de métal près de la trajectoire de coupe.
- Ne jamais pointer la torche vers soi ou d'autres personnes.



LES RAYONS DE L'ARC PEUVENT BRÛLER LES YEUX ET LA PEAU

Protection des yeux Les rayons de l'arc plasma produisent de puissants rayons visibles ou invisibles (ultraviolets et infrarouges) qui peuvent brûler les yeux et la peau.

- Utiliser des lunettes de sécurité conformément aux codes locaux ou nationaux en vigueur.
- Porter des lunettes de protection (lunettes ou masque muni d'écrans latéraux ou encore masque de soudure) avec des verres teintés appropriés pour protéger les yeux des rayons ultraviolets et infrarouges de l'arc.

- Gants à crispin, chaussures et casque de sécurité.
- Vêtements ignifuges couvrant toutes les parties exposées du corps.
- Pantalon sans revers pour éviter que des étincelles ou des scories puissent s'y loger.
- Avant le coupage, retirer de ses poches tout objet combustible comme les briquets au butane ou les allumettes.

Zone de coupage Préparer la zone de coupage afin de réduire la réverbération et la transmission de la lumière ultraviolette :

- Peindre les murs et autres surfaces de couleur sombre pour réduire la réflexion de la lumière.
- Utiliser des écrans et autres dispositifs de protection afin de protéger les autres personnes de la lumière et de la réverbération.
- Prévenir les autres personnes de ne pas regarder l'arc. Utiliser des affiches ou des panneaux.

Courant de l'arc	Puissance des verres teintés	
	AWS (É.-U.)	ISO 4850
Jusqu'à 100 A	N° 8	N° 11
100-200 A	N° 10	N° 11-12
200-400 A	N° 12	N° 13
Plus de 400 A	N° 14	N° 14

Protection de la peau Porter des vêtements de sécurité pour se protéger contre les brûlures que peuvent causer les rayons ultraviolets, les étincelles et le métal brûlant :



MISE À LA MASSE ET À LA TERRE

Câble de retour Bien fixer le câble de retour (ou de masse) à la pièce à couper ou à la table de travail de façon à assurer un bon contact métal-métal. Ne pas fixer le câble de retour à la partie de la pièce qui doit se détacher.

Table de travail Raccorder la table de travail à la terre, conformément aux codes de sécurité locaux ou nationaux appropriés.

Alimentation

- S'assurer que le fil de terre du cordon d'alimentation est connecté à la terre dans le coffret du sectionneur.
- S'il est nécessaire de brancher le cordon d'alimentation à la source de courant lors de l'installation du système, s'assurer que le fil de terre est correctement branché.
- Placer tout d'abord le fil de terre du cordon d'alimentation sur le plot de mise à la terre puis placer les autres fils de terre par-dessus. Bien serrer l'écrou de retenue.
- S'assurer que toutes les connexions sont bien serrées pour éviter la surchauffe.

SÉCURITÉ DES BOUTEILLES DE GAZ COMPRIMÉ

- Ne jamais lubrifier les robinets des bouteilles ou les régulateurs avec de l'huile ou de la graisse.
- Utiliser uniquement les bouteilles, régulateurs, tuyaux et accessoires appropriés et conçus pour chaque application spécifique.
- Entretenir l'équipement et les pièces d'équipement à gaz comprimé afin de les garder en bon état.
- Étiqueter et coder avec des couleurs tous les tuyaux de gaz afin d'identifier le type de gaz contenu dans chaque tuyau. Se référer aux codes locaux ou nationaux en vigueur.



LES BOUTEILLES DE GAZ COMPRIMÉ PEUVENT EXPLOSER EN CAS DE DOMMAGES

Les bouteilles de gaz contiennent du gaz à haute pression. Si une bouteille est endommagée, elle peut exploser.

- Manipuler et utiliser les bouteilles de gaz comprimé conformément aux codes locaux ou nationaux.
- Ne jamais utiliser une bouteille qui n'est pas placée à la verticale et bien assujettie.
- Le capuchon de protection doit être placé sur le robinet sauf si la bouteille est en cours d'utilisation ou connectée pour utilisation.
- Éviter à tout prix le contact électrique entre l'arc plasma et une bouteille.
- Ne jamais exposer des bouteilles à une chaleur excessive, aux étincelles, aux scories ou aux flammes nues.
- Ne jamais utiliser des marteaux, des clés ou d'autres outils pour débloquer le robinet des bouteilles.



LE BRUIT PEUT PROVOQUER DES PROBLÈMES AUDITIFS

Une exposition prolongée au bruit du coupage ou du gougeage peut provoquer des problèmes auditifs.

- Utiliser un casque de protection homologué lors de l'utilisation du système plasma.
- Prévenir les personnes aux alentours des risques encourus en cas d'exposition au bruit.



PACEMAKERS ET PROTHÈSES AUDITIVES

Les champs magnétiques produits par les courants à haute tension peuvent affecter le fonctionnement des prothèses auditives et des pacemakers. Les personnes portant ce type d'appareil doivent consulter un médecin avant de s'approcher d'un lieu où s'effectue le coupage ou le gougeage plasma.

Pour réduire les risques associés aux champs magnétiques :

- Garder loin de soi et du même côté du corps le câble de retour et le faisceau de la torche.
- Faire passer le faisceau de la torche le plus près possible du câble de retour.
- Ne pas s'enrouler le faisceau de la torche ou le câble de retour autour du corps.
- Se tenir le plus loin possible de la source de courant.

Section 2

DESCRIPTION & SPECIFICATIONS

In this section

INTRODUCTION.....	2-2
SPECIFICATIONS.....	2-3
PAC121 50A Torches	2-4
IEC SYMBOLS USED	2-6

DESCRIPTION & SPECIFICATIONS

INTRODUCTION

The Powermax800 plasma cutting system uses an inverter power supply to provide a smooth DC output voltage producing excellent cut and gouge quality on mild steel, stainless steel, aluminum and other metals. The Powermax800 power supply provides constant-current output variable from 20 to 50 amps, for optimum performance on all thicknesses of metal up to 1/2 inch (12 mm) thick. At 50 amps, the Powermax800 can cut metals up to 3/4 inch (20 mm) thick and will sever metals up to 1 inch (25 mm) thick.

Air is the primary plasma gas, providing low operating cost combined with high-speed performance. Cylinder air or shop air can be used as long as it is clean, dry and oil-free. When properly set and maintained, the pressure regulator and gas filter on the power supply ensure that the correct pressure and flow rate is supplied to the system at the proper quantity and quality. The Powermax800 can also cut with nitrogen when extended electrode life is a priority.

This service manual provides information for qualified service technicians to troubleshoot and repair the power supply and torch. Sections 4 and 5 contain in-depth parts lists of the Powermax800 systems. This manual also provides a detailed list of safety practices, so that the system can be safely tested and maintained. **READ THE SAFETY SECTION (Section 1) FIRST!**

The Powermax800 operator manual provides setup and daily operating instructions.

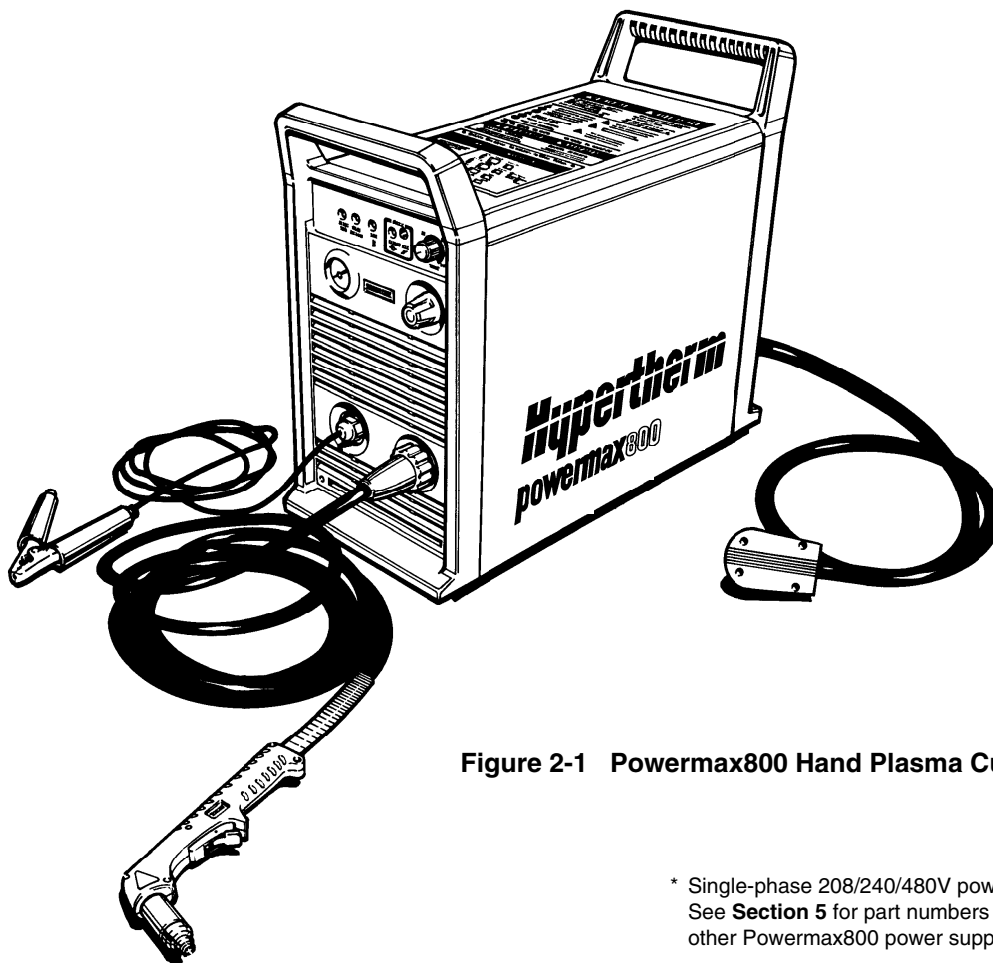

Figure 2-1 Powermax800 Hand Plasma Cutting System*

* Single-phase 208/240/480V power supply shown.
See **Section 5** for part numbers and descriptions of other Powermax800 power supplies.

DESCRIPTION & SPECIFICATIONS

SPECIFICATIONS

Power Supply

Rated Open Circuit Voltage (OCV) (U_0)	300VDC
Rated Output Current (I_2)	20-50 amps
Rated Output Voltage (U_2)	120VDC
Duty Cycle (X) @ 40°C	50% ($I_2=50A$, $U_2=120V$) 100% ($I_2=44A$, $U_2=97V$) See data tag on power supply for more information on duty cycle
Ambient temperature/duty cycle	Power supplies will operate between +14° and 104° F (-10° and +40° C). Power supplies operated in an ambient temperature above 86° F (30° C) may show some decrease in duty cycle.
Apparent Input Power (S_1)	10.4kVA (U_1I_1)
Input Voltage (U_1)/Input Current (I_1) @ 6 kw Output	208V/50A; 240V/43A; 480V/25A - 1 ϕ , 60 Hz 208V/29A; 240V/25A; 480V/13A - 3 ϕ , 60 Hz 200V/52A; 230V/45A; 400V/30A - 1 ϕ , 50/60 Hz 200V/30A; 230V/26A; 400V/16A - 3 ϕ , 50/60 Hz 400V (CE)/16A - 3 ϕ , 50/60 Hz 600V/11A - 3 ϕ , 60 Hz
Dimensions and Weight:	
Depth	23.1" (590 mm)
Width	10.4" (260 mm) without wheels 15.25" (390 mm) with wheels
Height	19.6" (500 mm) without wheels 23.7" (620 mm) with wheels 27.7" (700 mm) for 600V power supply

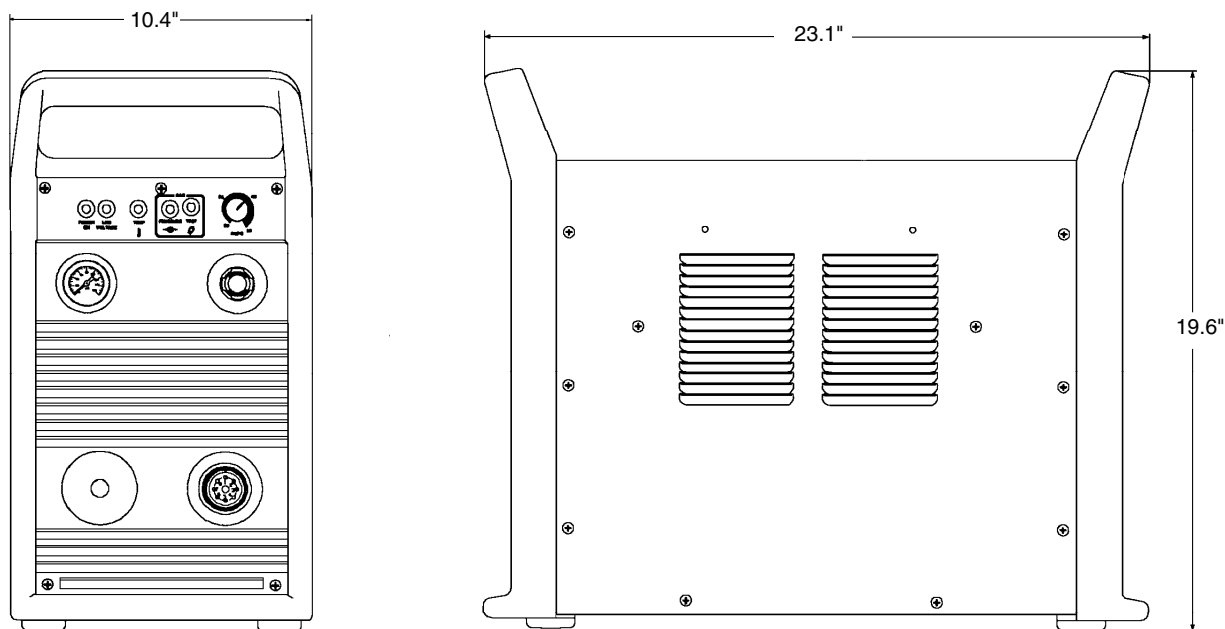

Figure 2-2 Powermax800 Power Supply with Dimensions

DESCRIPTION & SPECIFICATIONS

Weight	65 pounds (30 kg) without wheels 72 pounds (33 kg) with wheels 128 pounds (58 kg) for 600V power supply
Gas Type	Air or Nitrogen
Gas Quality, Air	Clean, dry, oil-free
Gas Quality, Nitrogen	99.995% pure
Gas Inlet Pressure	90 psi (6.2 bar)
Gas Flow	320 scfh/5.3 scfm at 90 psi (150 l/min at 6.2 bar) supplied to power supply pressure regulator
Power Supply pressure regulator setting	70 psi (4.8 bar) flowing

PAC121 50A TORCHES

Maximum 50A Cutting Capacity (PAC121TS)	3/4" (20 mm) @ 50% duty cycle
Maximum 50A Cutting Capacity (PAC121MS)	3/8" (10 mm) @ 50% duty cycle
Maximum 35A Cutting Capacity (PAC121MS)	1/4" (6 mm) @ 100% duty cycle
Maximum current at 50% duty cycle	50 amps
Gas Flow	320 scfh/5.3 scfm at 70 psi (150 l/min at 4.8 bar)
Gouging Capability (metal removal rate)	6.3 pounds (2.9 kg)/hr
Weight PAC121TS	4.5 pounds (2 kg) with 25 ft (7.6 m) lead 7 pounds (3.2 kg) with 50 ft (15 m) lead
Weight PAC121MS	7 pounds (3.2 kg) with 25 ft (7.6 m) lead 9.5 pounds (4.3 kg) with 50 ft (15 m) lead

PAC121TS Hand Torch Assembly

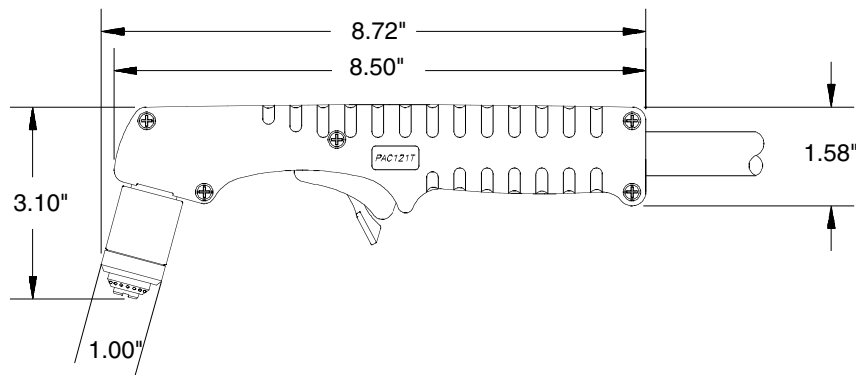

Figure 2-3 PAC121TS Torch with Dimensions

PAC121MS Machine Torch Assembly

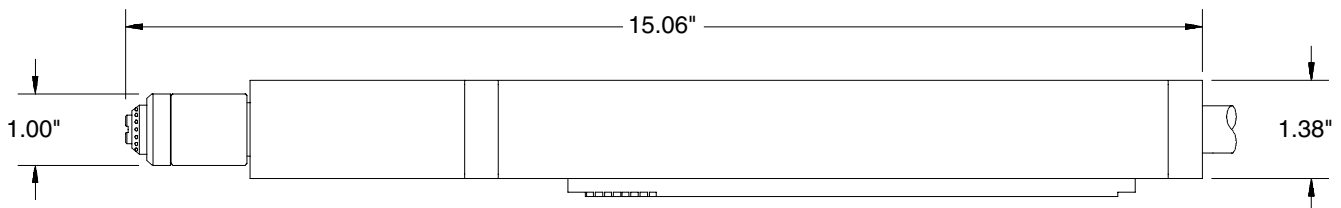



Figure 2-4 PAC121MS Torch with Dimensions

S MARK

The Powermax800 conforms to **CE** standard EN50192. The **S** mark indicates that the power supply and torch are suitable for use in environments with increased hazard of electrical shock. The torches must have shielded consumable parts to maintain **S** mark compliance. See warning below and Figure 2-5.



WARNING



The voltage between the tip of the torch and the workpiece will exceed 113VDC if shielded consumable parts are not installed in the torch. If using the 400V CE power supply, the PAC121TS torch must be operated with shielded parts to maintain the **S** mark and CE low-voltage compliance for hand held applications. See Figure 2-5 below and also Section 5: *Consumable Parts - For CE Compliance* for a list of CE consumable parts. This requirement does not apply to machine torch applications.

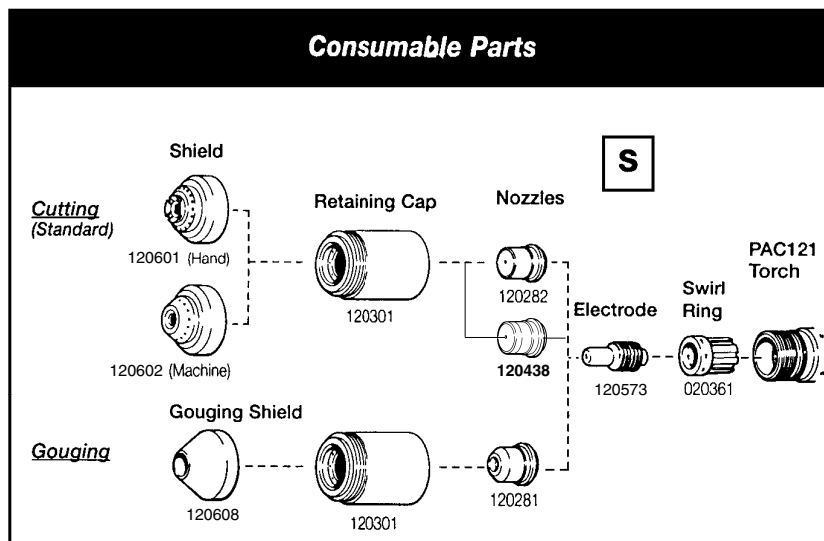















Figure 2-5 **S** Mark Label.

DESCRIPTION & SPECIFICATIONS

IEC SYMBOLS USED

	Direct Current (DC)
	Alternating current (AC)
	Plasma cutting torch
	AC input power connection
	The terminal for the external protective (earth) conductor
	An inverter-based power source
	Anode (+) work clamp
	Temperature switch
	Pressure switch
	Plasma torch in the TEST position (cooling and cutting gas exiting nozzle)
	Power is on
	Power is off
	Volt/amp curve, "drooping" characteristic

Section 3 MAINTENANCE

In this section:

Introduction	3-2
Routine Maintenance	3-2
Bowl Draining/Filter Element Cleaning	3-2
Cooling Air Filter Removal, Cleaning and Replacement.....	3-3
Theory of Operation	3-4
Sequence of Operation	3-6
Troubleshooting	3-7
Test Equipment	3-7
Troubleshooting Procedures	3-7
Visual Inspection - External	3-7
Visual Inspection - Internal	3-8
Initial Resistance Checks	3-9
Corrective Maintenance Checks	3-17
Power Board	3-26
Control Board	3-28
Control Board LEDs.....	3-28
Control Board Test Points	3-29
Torch Check	3-30
Cap Sensor Circuit Check	3-30
Start Circuit Check.....	3-31
PAC121TS Torch Parts Removal and Replacement	3-32
Torch Main Body Removal and Replacement	3-32
Torch Switch Removal and Replacement	3-33
PAC121MS Torch Parts Removal and Replacement	3-34
Removal	3-34
Replacement	3-34
Quick Disconnect O-Ring Removal and Replacement	3-36

INTRODUCTION

This section provides service technicians with routine maintenance, theory of operation and troubleshooting of the power supply. Also included in this section is the sequence of operation, power board and control board test points, and the removal and replacement procedures for the PAC121T trigger torch and PAC121M machine torch parts.

ROUTINE MAINTENANCE

Bowl Draining/Filter Element Cleaning

Moisture coming out of the torch can cause the torch to sputter and hiss. If there is moisture, purge the lines. If moisture builds up in the bowl of the filter at the rear of the power supply, drain the bowl and clean the filter element:

1. **Shut the gas supply off and disconnect** the gas supply hose from the filter assembly before proceeding.
2. Remove the cap at the bottom of the filter bowl and turn the knurled drain valve to the right to release water from the bowl.

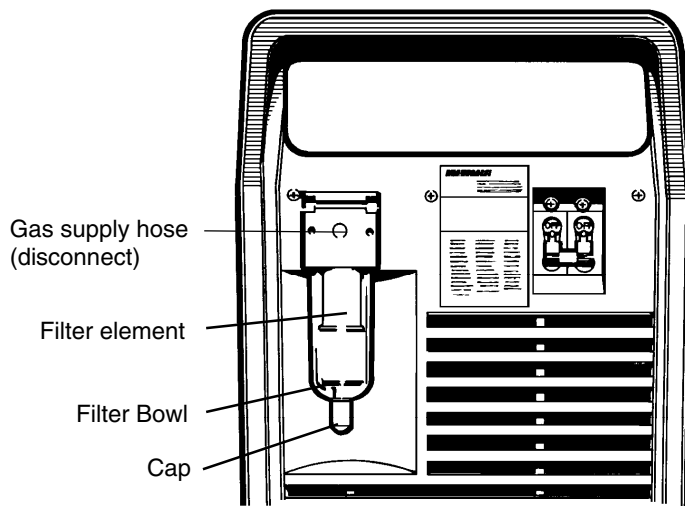

Figure 3-1 Filter Assembly

3. Unscrew the filter bowl.
4. Unscrew the filter element. See *Powermax800 Field Upgrade Kits and Optional Parts* in **Section 4** for part number information.
5. Clean filter element with alcohol, then blow out with air from the inside of the filter element. Clean the bowl with household soap only.
6. Replace the filter element and filter bowl.
7. Reconnect the gas supply hose.

Cooling Air Filter Removal, Cleaning and Replacement

Powermax800 systems are normally shipped without air filters. If your Powermax800 has the air filter option, it will need cleaning periodically. Excessively dirty or dusty environments can block the cooling air filter (if installed) and cause the power supply to overheat and shut down.



WARNING



SHOCK HAZARD: Always turn off power and unplug cord from wall and wait 5 minutes before removing any cover of the power supply. If power supply is directly connected to a line disconnect box, place line disconnect switch to OFF position. In the U.S., use a "lock-out / tag-out" procedure until the service or maintenance work is complete. In other countries, follow appropriate local or national safety procedures.

1. Turn the Powermax800 power switch to the OFF (0) position, unplug the power cable from the wall receptacle and disconnect the gas supply. See warning above.
2. Remove the 22 screws that secure the power supply cover to the chassis.
3. Remove the cover, and remove the cooling air filter from the clips by sliding the filter to the left and then up - Fig. 3-2.

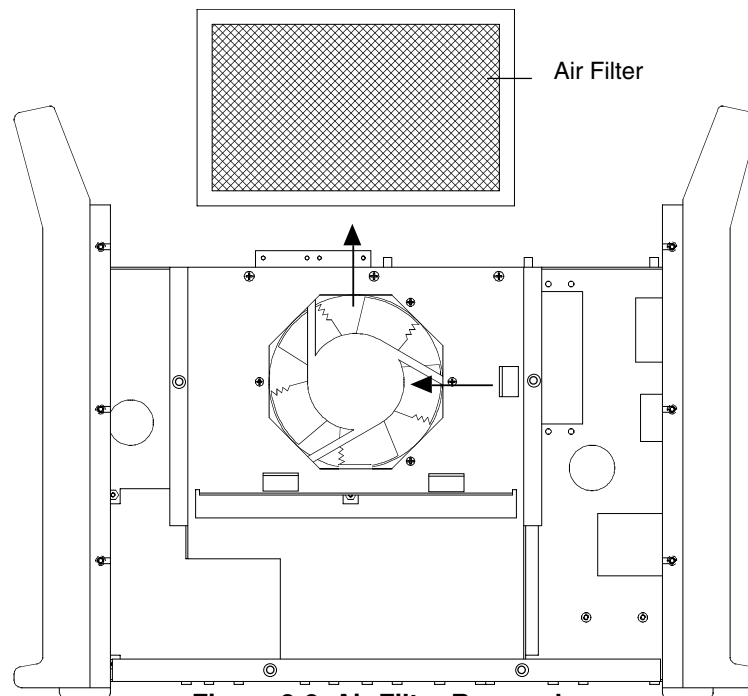

4. Clean the air filter with either soap and water or with low pressure compressed air.
5. Replace the dry filter in the power unit with the wire mesh facing the fan.
6. Replace and re-fasten the power supply cover with the existing screws.

THEORY OF OPERATION

General

The Powermax800 is a multi-voltage, multi-phase power supply. The two inverter inputs are linked in *parallel* for 208 or 240V on the 208/240/480V units, and for 200 or 230V on the 200/230/400V units. The inverters are linked in *series* for 480V on the 208/240/480V units, and for 400V on the 200/230/400V units. The inverter links are located in the link box, behind the rear panel at TB3. See Fig. 3-3. The 400V CE power supply does not have a link box.

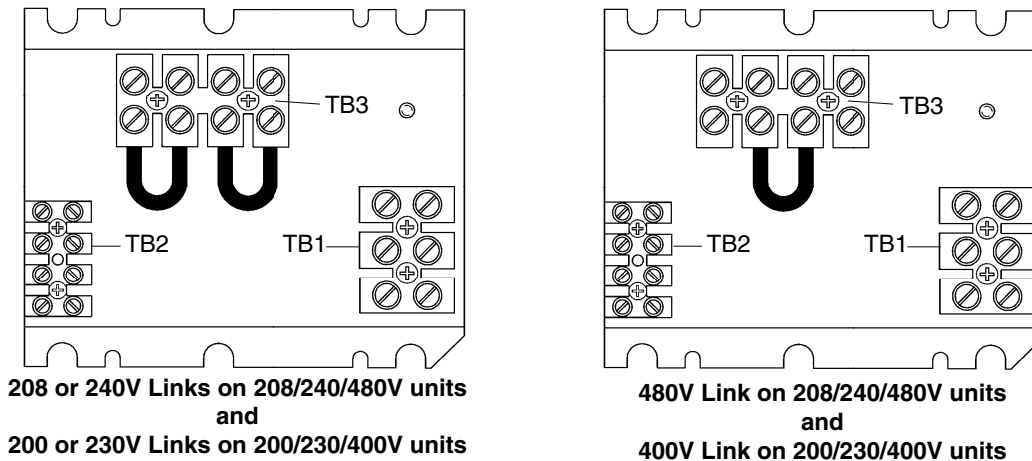

Figure 3-3 Inverter Links

Functional Description

Refer to block diagram 3-4, Figure 3-3 and the system wiring diagram. See **Section 4: Parts List** to identify system components referenced in this description.

AC power enters power switch S1 from terminal block TB1. The MOV and filter capacitor block MOV1 provides spike and noise suppression. A "soft start" is implemented via power board resistors R1 and R2 and relay RL1, and the main contactor CR1. Once the capacitors on the power board are charged up and incoming power is within limits, the control board turns on the main contactor. Diode bridge D1 rectifies the AC to DC. The DC voltage is then supplied to the inverters.

Each inverter consists of several components: an isolated gate bipolar transistor (IGBT - Q1 or Q2), a coil of the power transformer (T2), a current sense transformer (CS1 or CS2), and sections of the power board. The inverters operate as a pulse width modulator controlled half-bridge circuit. The inverters are capacitor fed and transformer coupled, switching at 20 KHZ. The inverter outputs are connected in series, and are rectified by output diodes D2 and D3.

The output circuitry consists of a current sensor CS4 and transfer sensor CS3 located on the control board, pilot arc relay CR2, and output inductor L1.

The feedback loop operates as follows: The amp adjust pot P1 is first set to the desired value. Current sensor CS4 measures the actual output current and compares it at the error amplifier with the user-set current setting. The error amplifier output is an analog indication of how wide the pulse width should be to maintain the current setting. The error amplifier output is then fed to the pulse width modulator chip PWM. The pulse width modulator sends the signal to the gate drive board transformers, and the gate drive boards in turn drive the inverter IGBTs Q1 and Q2.

SEQUENCE OF OPERATION

Shaded boxes represent operator action. Clear boxes represent results from operator action.

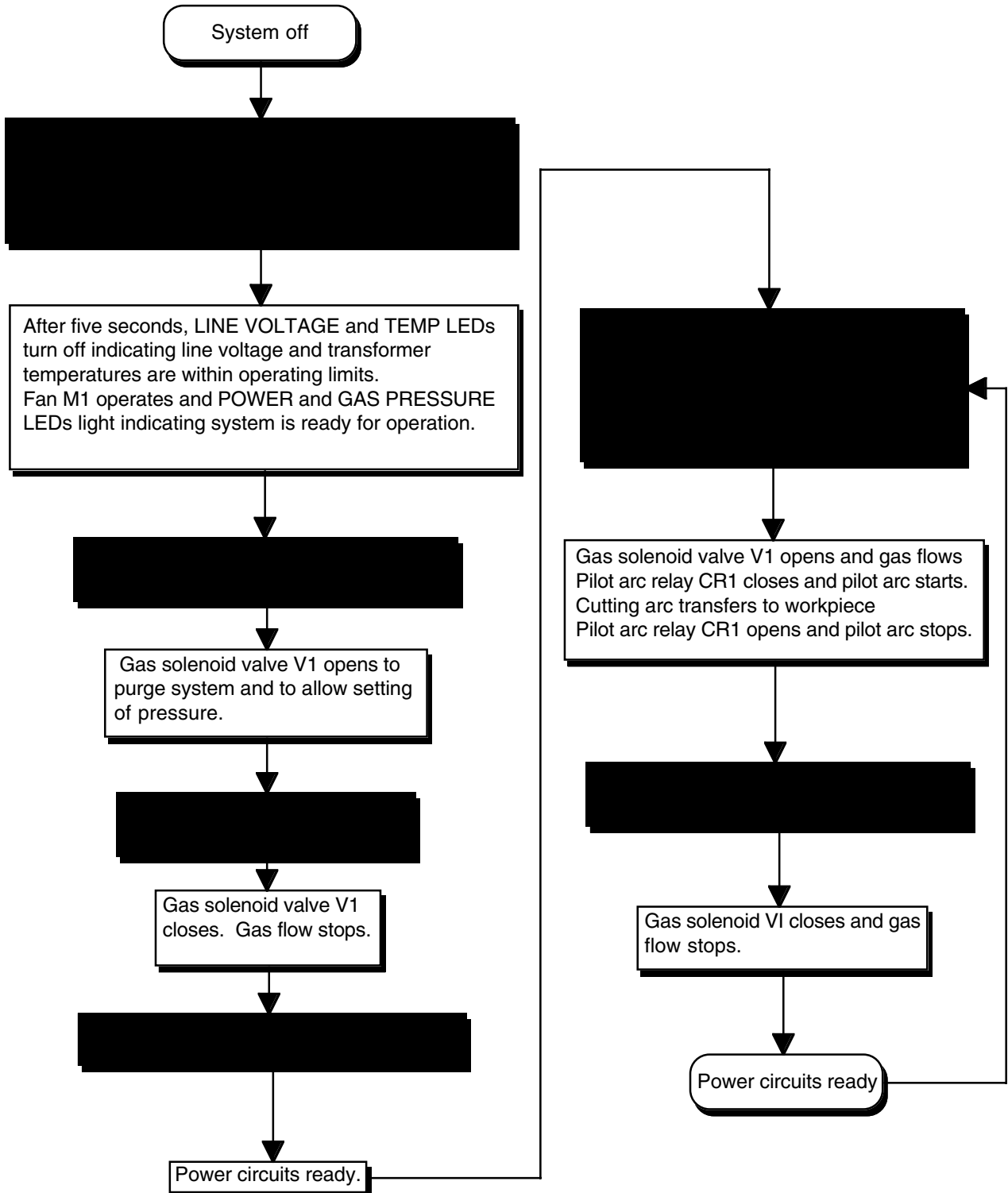

TROUBLESHOOTING

The troubleshooting procedures include the *Initial Resistance Checks* and the *Corrective Maintenance Checks*. These procedures are presented in a flow diagram format.

The complexity of the circuits require that service technicians have a working knowledge of inverter power supply theory. In addition to being technically qualified, technicians must perform all testing with safety in mind.

If questions or problems arise during servicing, call the Hypertherm Technical Services Department at 1 800 643 9878.

Test Equipment

- Multimeter

Troubleshooting Procedures

Maintenance of the Powermax800 power supply consists of performing visual inspection and troubleshooting procedures.

- Refer to the system wiring diagram when performing the checkout procedures.
- To locate power supply and torch components refer to **Section 4** for 208/240/480V and 200/230/400V power supplies, and **Section 5** for 400V CE power supplies.
- After the problem has been located and repaired, refer to the *Sequence of Operation* flow diagram in this section to test the power unit for proper operation.

Visual Inspection - External

1. Inspect the outside of the power supply for damage to the cover and external components.
2. Inspect the torch and the torch lead for damage.

Visual Inspection - Internal



WARNING



SHOCK HAZARD: Always turn off power and unplug cord from wall and wait 5 minutes before removing any cover of the power supply. If power supply is directly connected to a line disconnect box, place line disconnect switch to OFF position. In the U.S., use a "lock-out / tag-out" procedure until the service or maintenance work is complete. In other countries, follow appropriate local or national safety procedures.

If power is required for servicing, be aware that dangerous voltages exist within the power supply which could cause serious injury or death. If questions or problems arise during servicing, call the Hypertherm Technical Services department at 1-800-643-9878.



WARNING



The aluminum heatsink on the power PC board is electrically live when the plasma is on. In case of an electrical failure of the inverter circuit, the heatsink may be live when the power is off.

SHOCK HAZARD: The large electrolytic capacitors, (blue-cased cylinders) located on the power PC board store large amounts of energy in the form of electrical voltage. Even if the power is off, dangerous voltages exist at the capacitor terminals on the PC board and on certain areas of the PC board. Never discharge the capacitors with a screwdriver or other implement... explosion, property damage and/or personal injury will result.

Wait at least 5 minutes after turning the power supply off before touching the PC board or capacitors. If questions or problems arise during servicing, call Hypertherm Technical Services at 1-800-643-9878.



WARNING



SHOCK HAZARD: Do not attempt repairs on the power board or control board. Do not in any way cut away or remove the protective conformal coating from either board. To do so will risk a short between the AC input circuit to the output circuit and may cause serious injury or death.

The power supply and PC boards are subjected to dielectric and insulation resistance tests per applicable CSA and IEC standards for the safety of the operator and service technicians.

Removal of the protective conformal coatings and other unauthorized repairs to the PC boards will void the warranty.

If questions or problems arise during servicing, call the Hypertherm Technical Services department at 1-800-643-9878.

1. Set the Powermax800 power switch to O (off), unplug the power cord, and disconnect the gas supply - see warnings.
2. Remove the cover of the power supply by removing 22 securing screws.
3. Visually inspect the inside of the power supply, especially on the side with the power board (see Figures 4-2 and 4-3). Look for broken or loose wiring connections, burn and char marks, damaged components, etc. Repair or replace as necessary.

Initial Resistance Checks

1. After visually inspecting the exterior and interior of the power supply, always perform the initial resistance checks before applying power to the power supply. **If these checks are not performed prior to power up, further damage to the power supply could result.**
2. Perform the initial resistance checks beginning on the following page.
3. After the problem has been located and repaired, refer to the *Sequence of Operation* flow diagram in this section to test the power unit for proper operation.

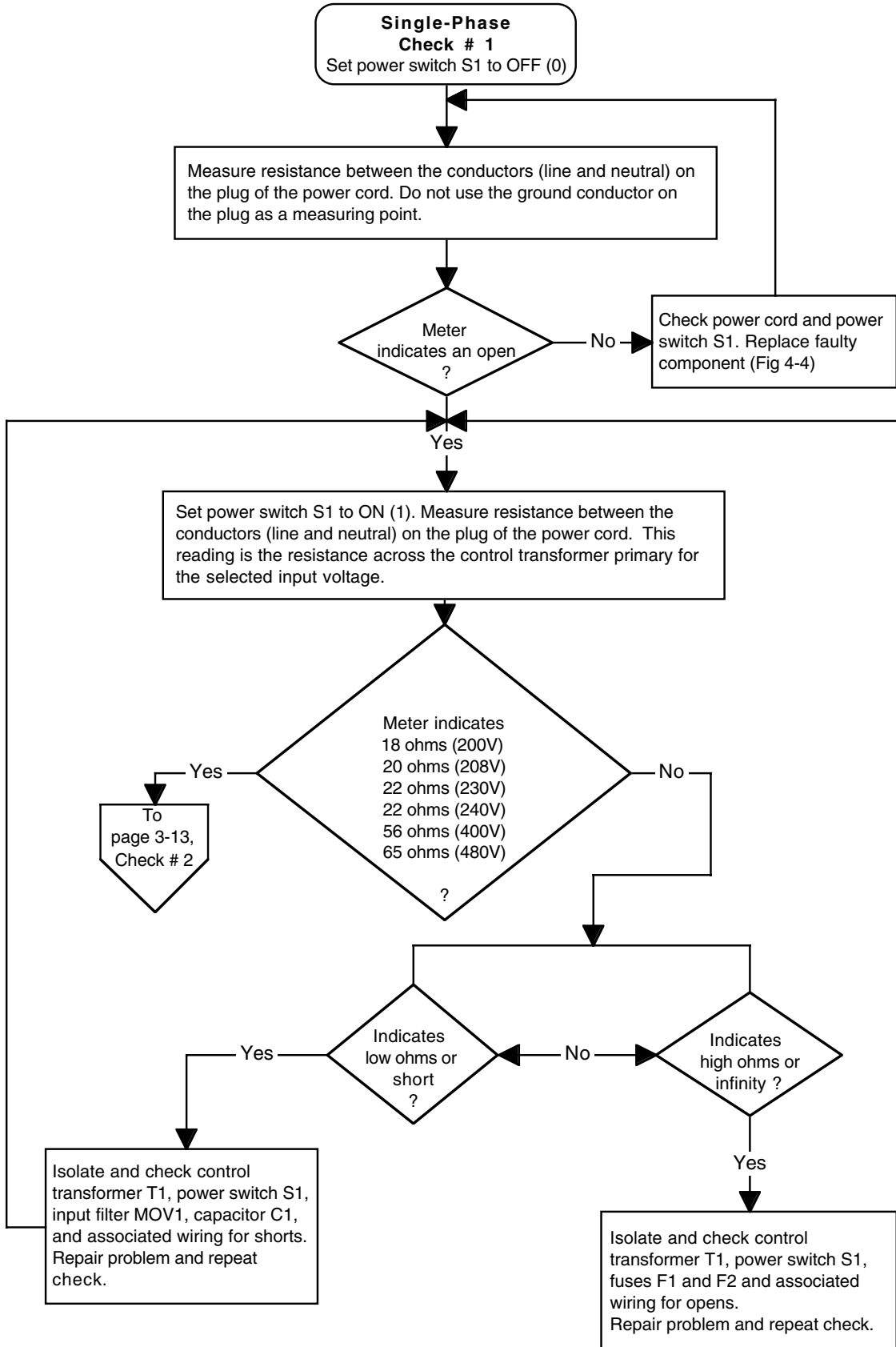

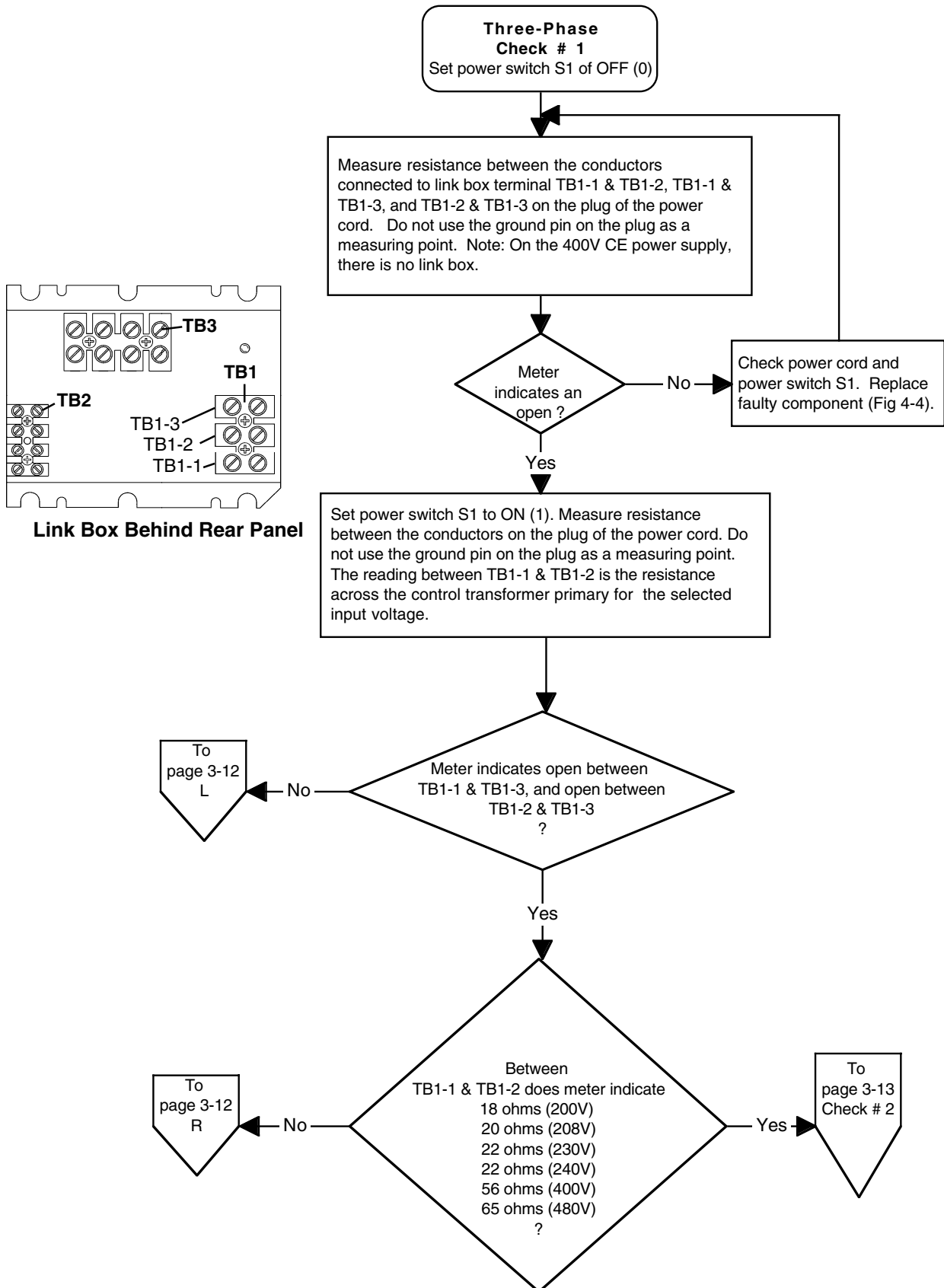

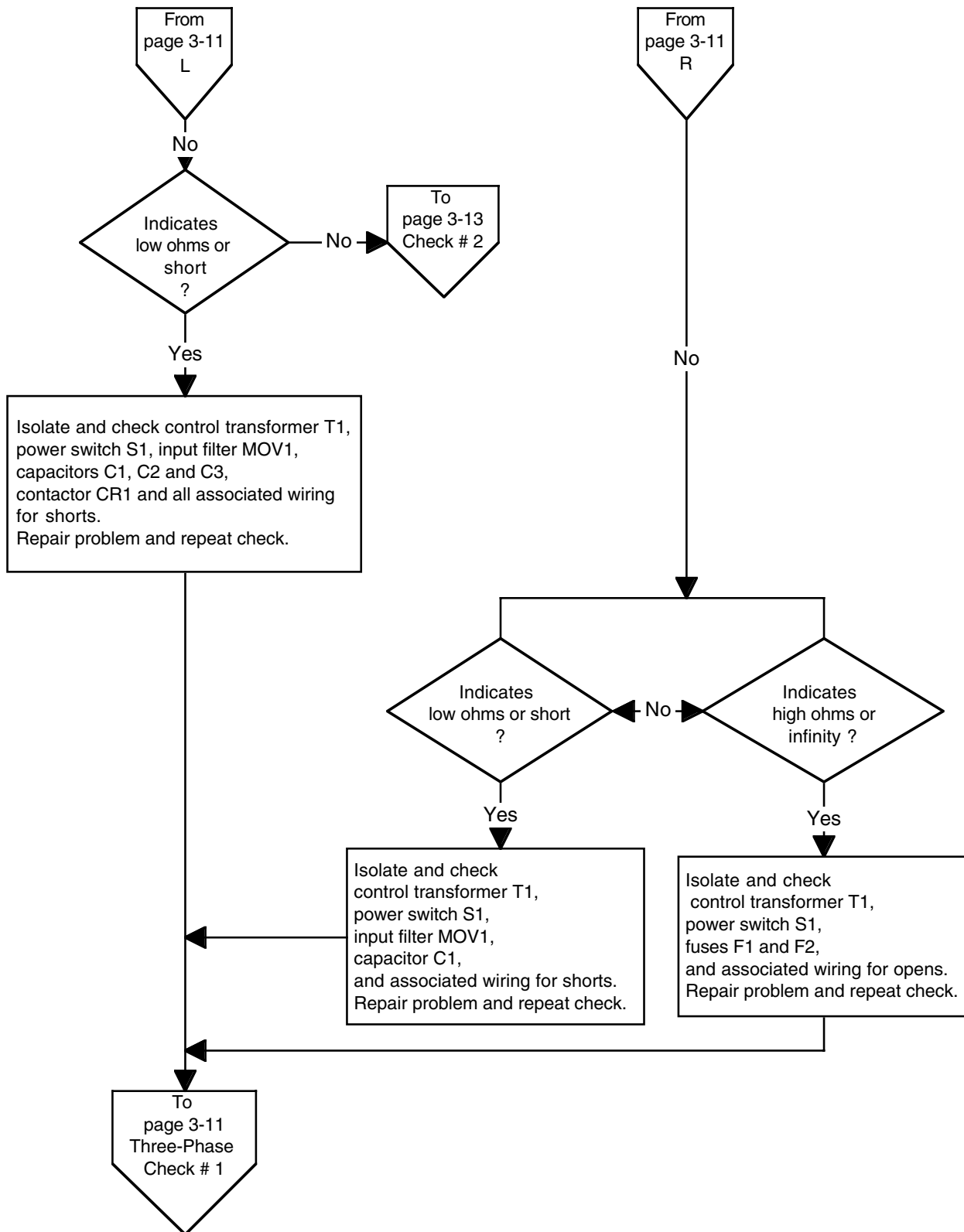

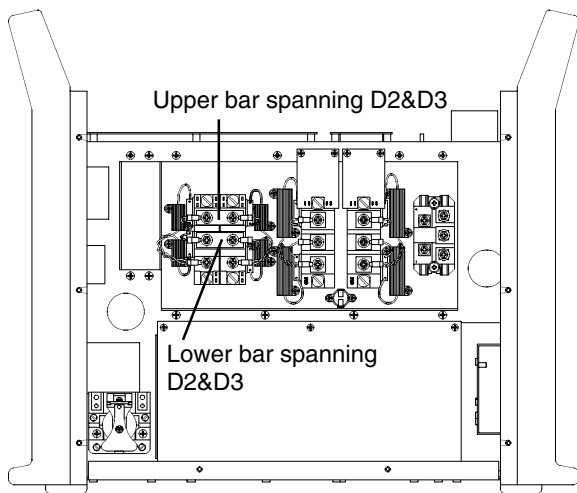
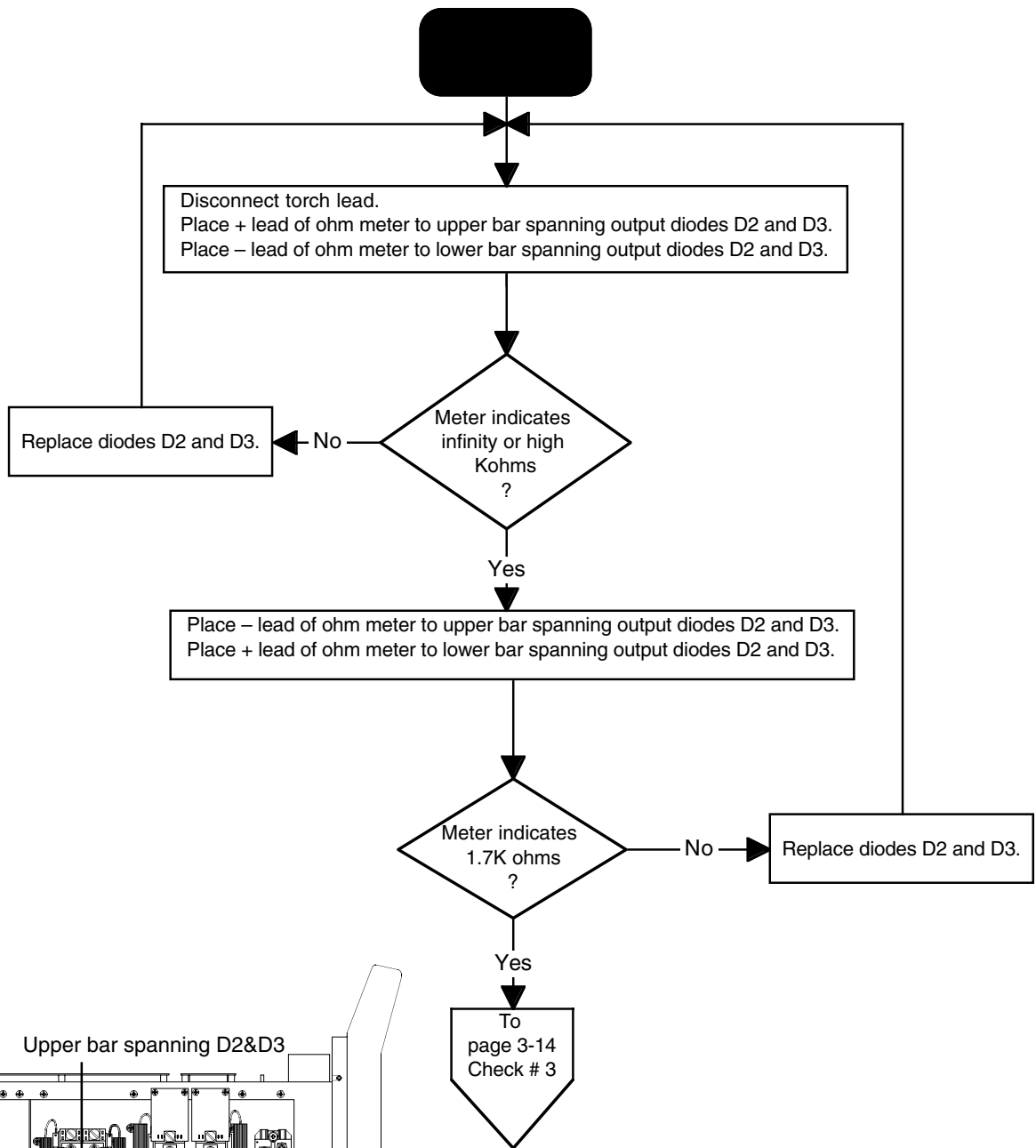

Location of Bars Spanning D2 and D3

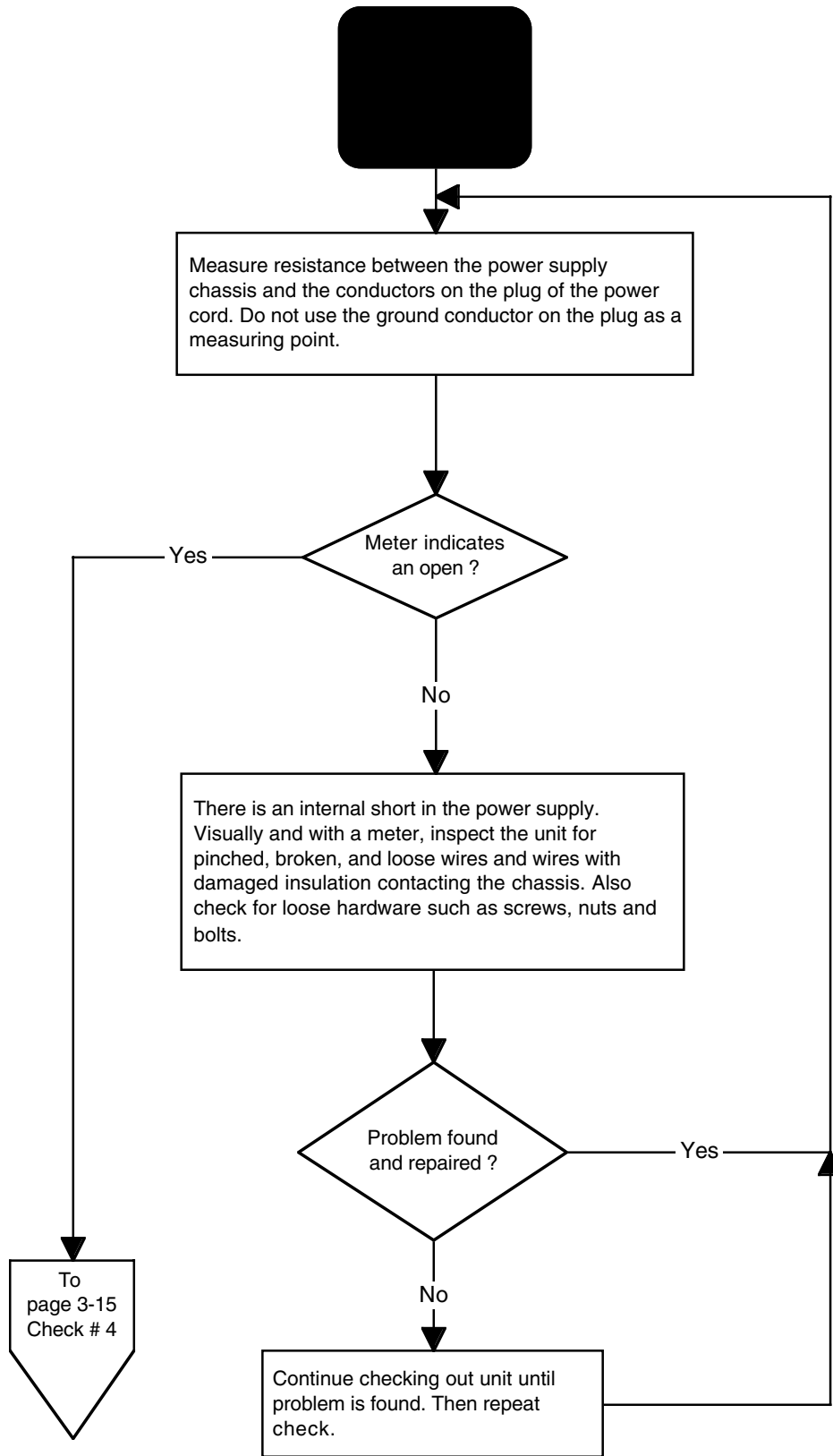

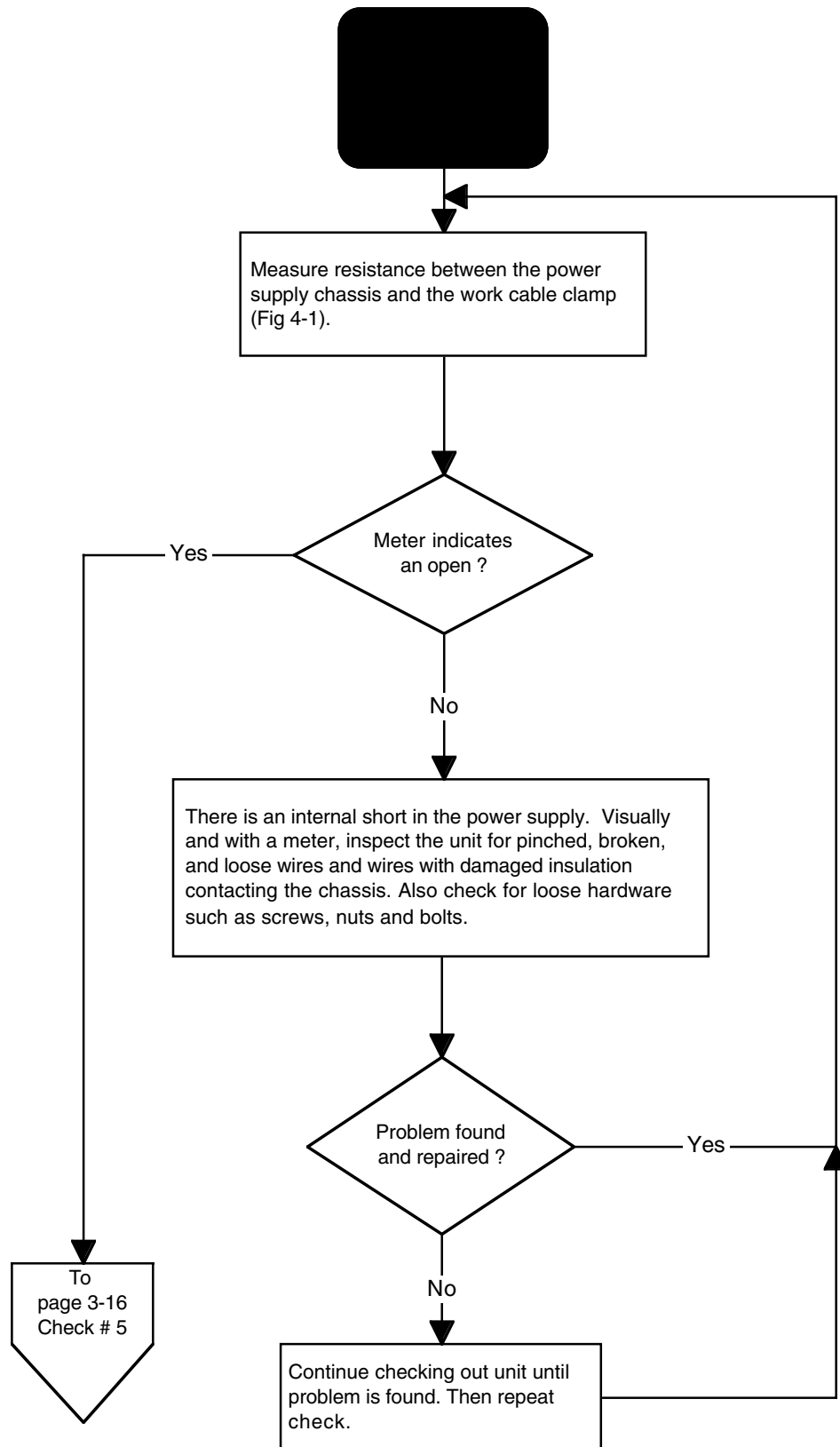

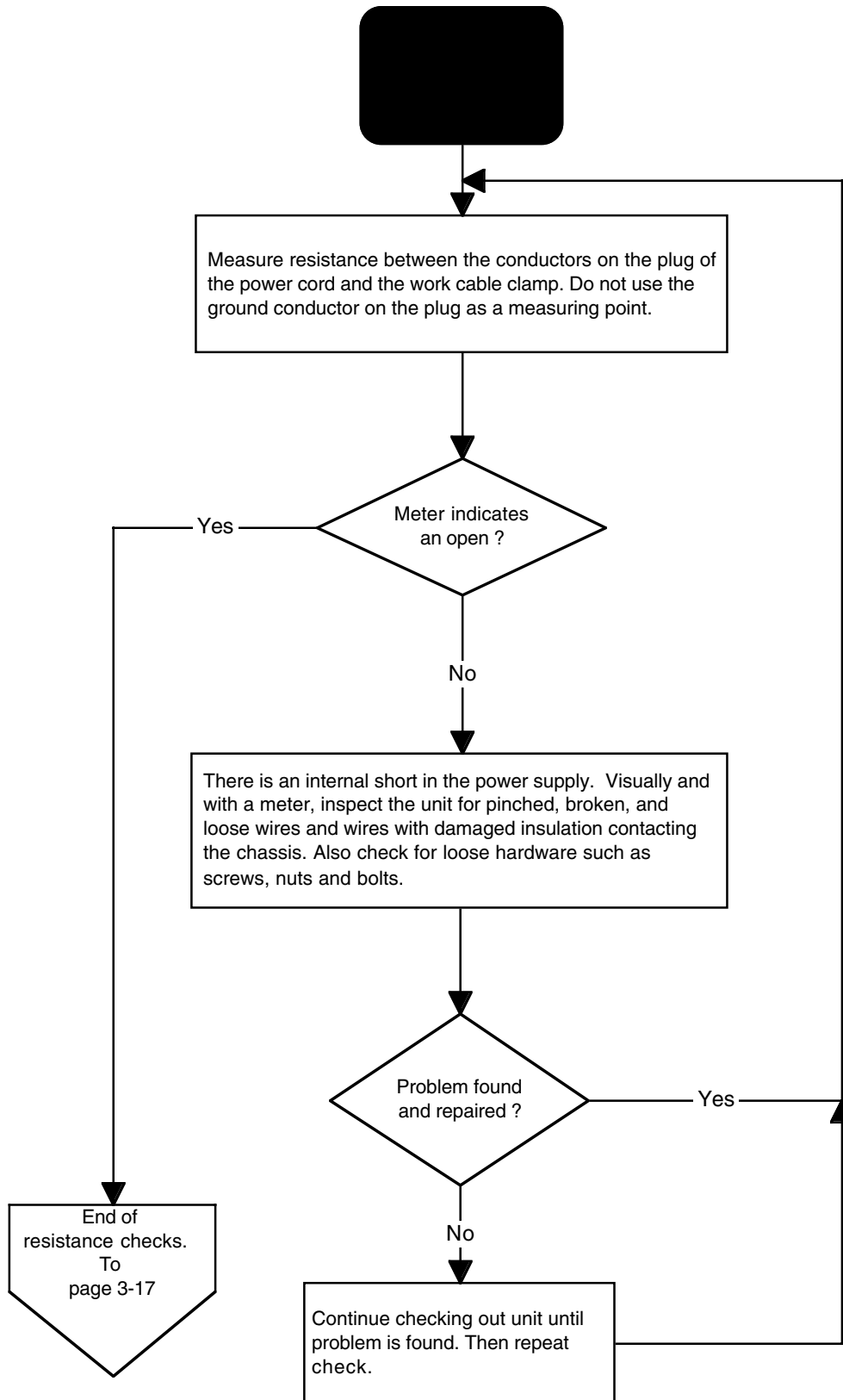

Corrective Maintenance Checks**WARNING**

SHOCK HAZARD: Always turn off power and unplug cord from wall and wait 5 minutes before removing any cover of the power supply. If power supply is directly connected to a line disconnect box, place line disconnect switch to OFF position. In the U.S., use a "lock-out / tag-out" procedure until the service or maintenance work is complete. In other countries, follow appropriate local or national safety procedures.

If power is required for servicing, be aware that dangerous voltages exist within the power supply which could cause serious injury or death. If questions or problems arise during servicing, call the Hypertherm Technical Services department at 1-800-643-9878.

**WARNING**

The aluminum heatsink on the power PC board is electrically live when the plasma is on. In case of an electrical failure of the inverter circuit, the heatsink may be live when the power is off.

SHOCK HAZARD: The large electrolytic capacitors, (blue-cased cylinders) located on the power PC board store large amounts of energy in the form of electrical voltage. Even if the power is off, dangerous voltages exist at the capacitor terminals on the PC board and on certain areas of the PC board. Never discharge the capacitors with a screwdriver or other implement... explosion, property damage and/or personal injury will result.

Wait at least 5 minutes after turning the power supply off before touching the PC board or capacitors. If questions or problems arise during servicing, call Hypertherm Technical Services at 1-800-643-9878.



WARNING



SHOCK HAZARD: Do not attempt repairs on the power board or control board. Do not in any way cut away or remove the protective conformal coating from either board. To do so will risk a short between the AC input circuit to the output circuit and may cause serious injury or death.

The power supply and PC boards are subjected to dielectric and insulation resistance tests per applicable CSA and IEC standards for the safety of the operator and service technicians.

Removal of the protective conformal coatings and other unauthorized repairs to the PC boards will void the warranty.

If questions or problems arise during servicing, call the Hypertherm Technical Services department at 1-800-643-9878.

If no problems were found during the initial resistance checks and the power supply still does not operate correctly, perform the following corrective maintenance checks.

Note: The corrective maintenance flow charts are "best-guess" solutions. Study the system wiring diagram and understand the theory of operation before troubleshooting. Before purchasing a major replacement component, check with Hypertherm's Technical Service group at 1 800 643 9878 or the nearest Hypertherm repair facility.

1. Connect the torch lead to the power supply.
2. Connect the power cord into the line voltage disconnect switch box or plug into a properly grounded outlet.
3. Connect the gas supply to the pressure regulator at the rear of the power supply.
4. Perform the corrective maintenance checks starting on the following page.
5. After the problem has been located and repaired, refer to the *Sequence of Operation* in this section for the normal operation of the power supply from power up to cutting.

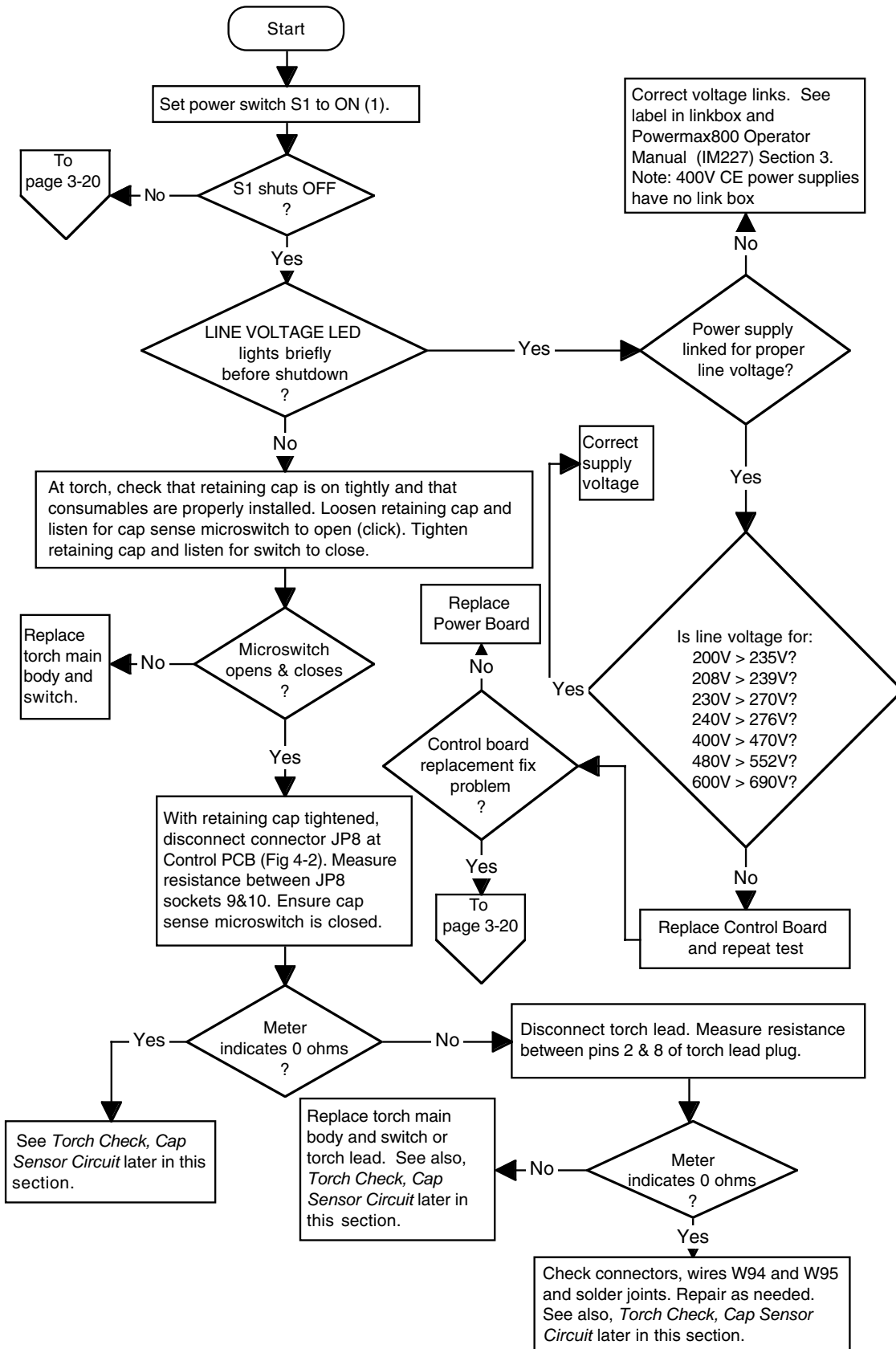

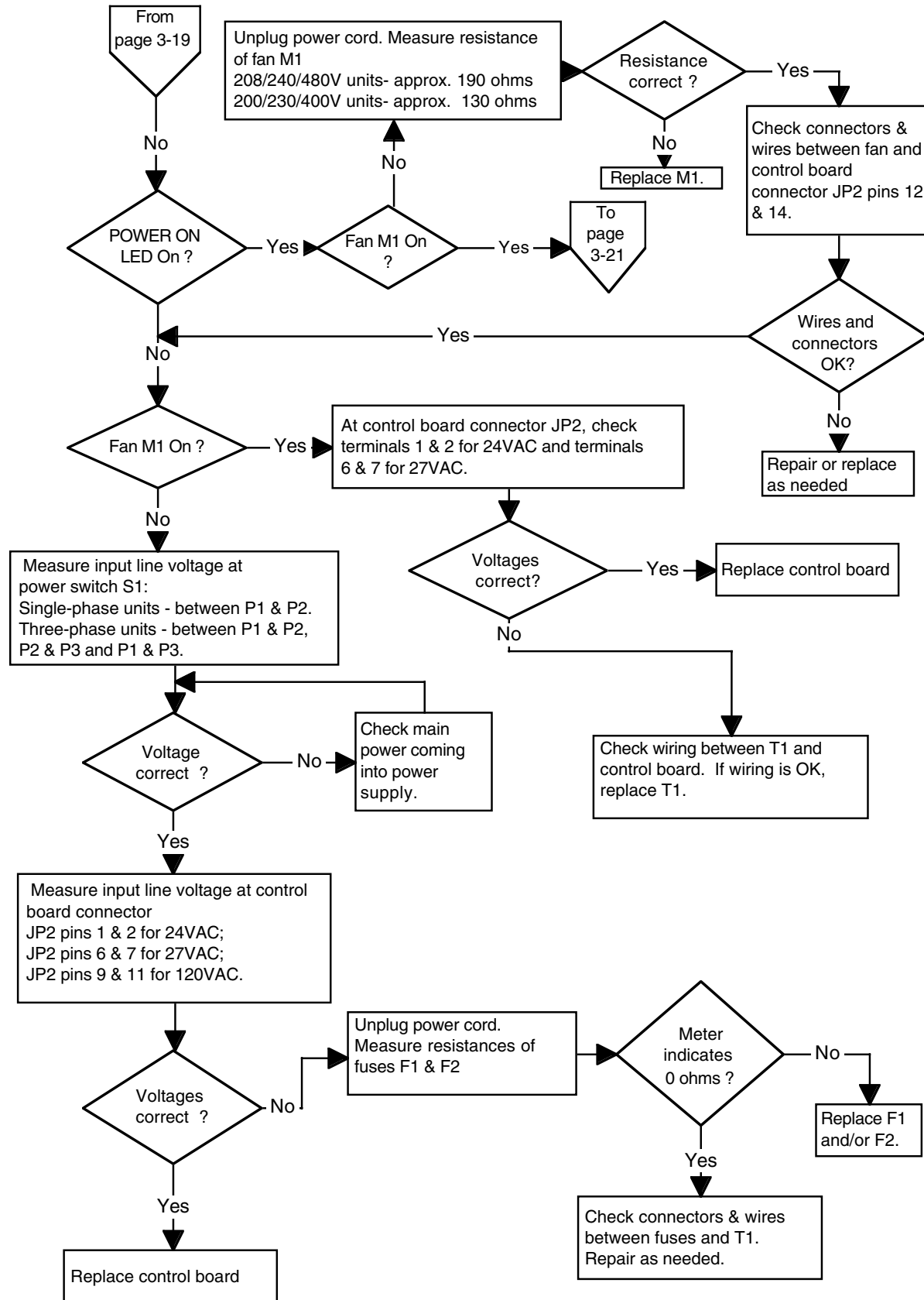

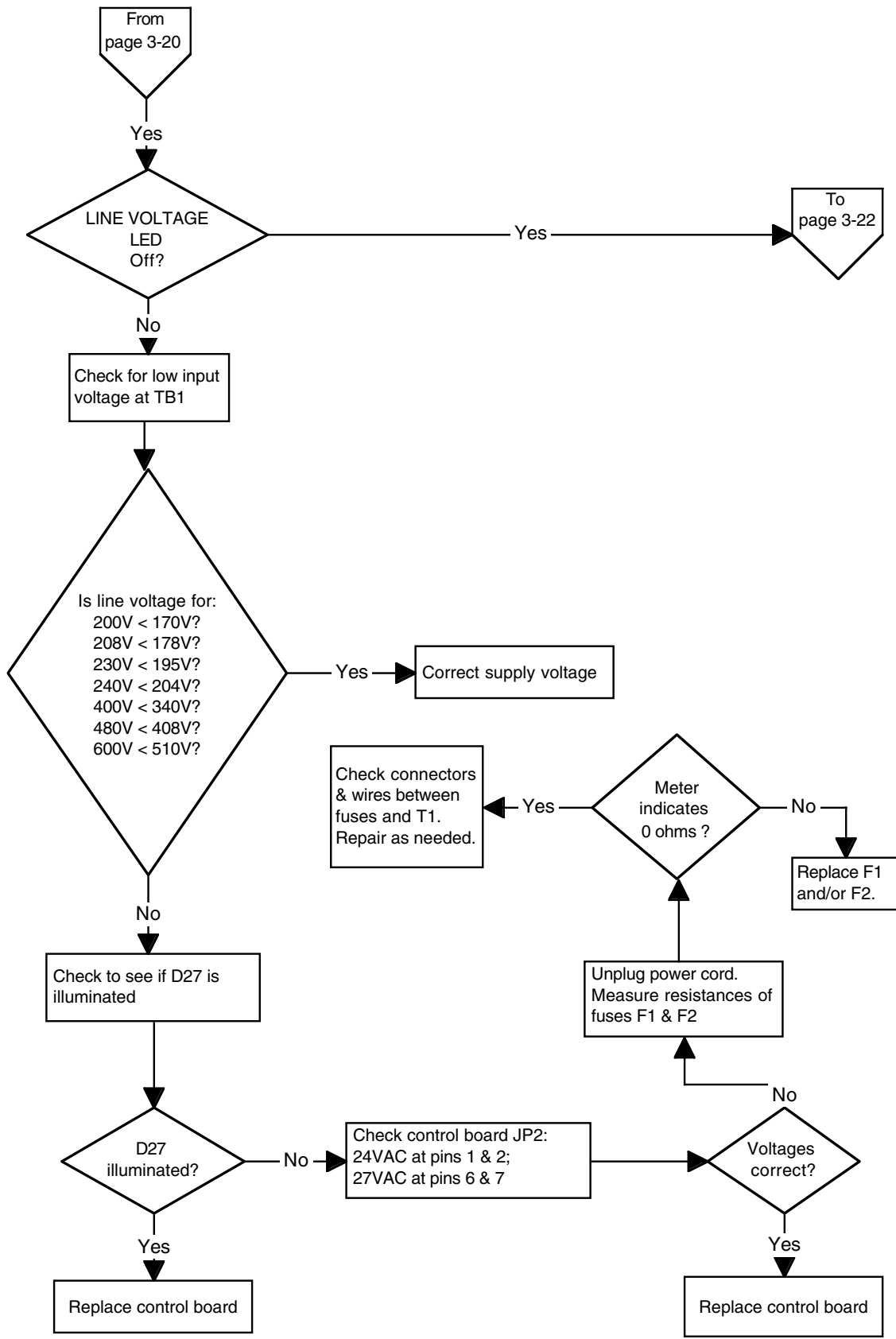

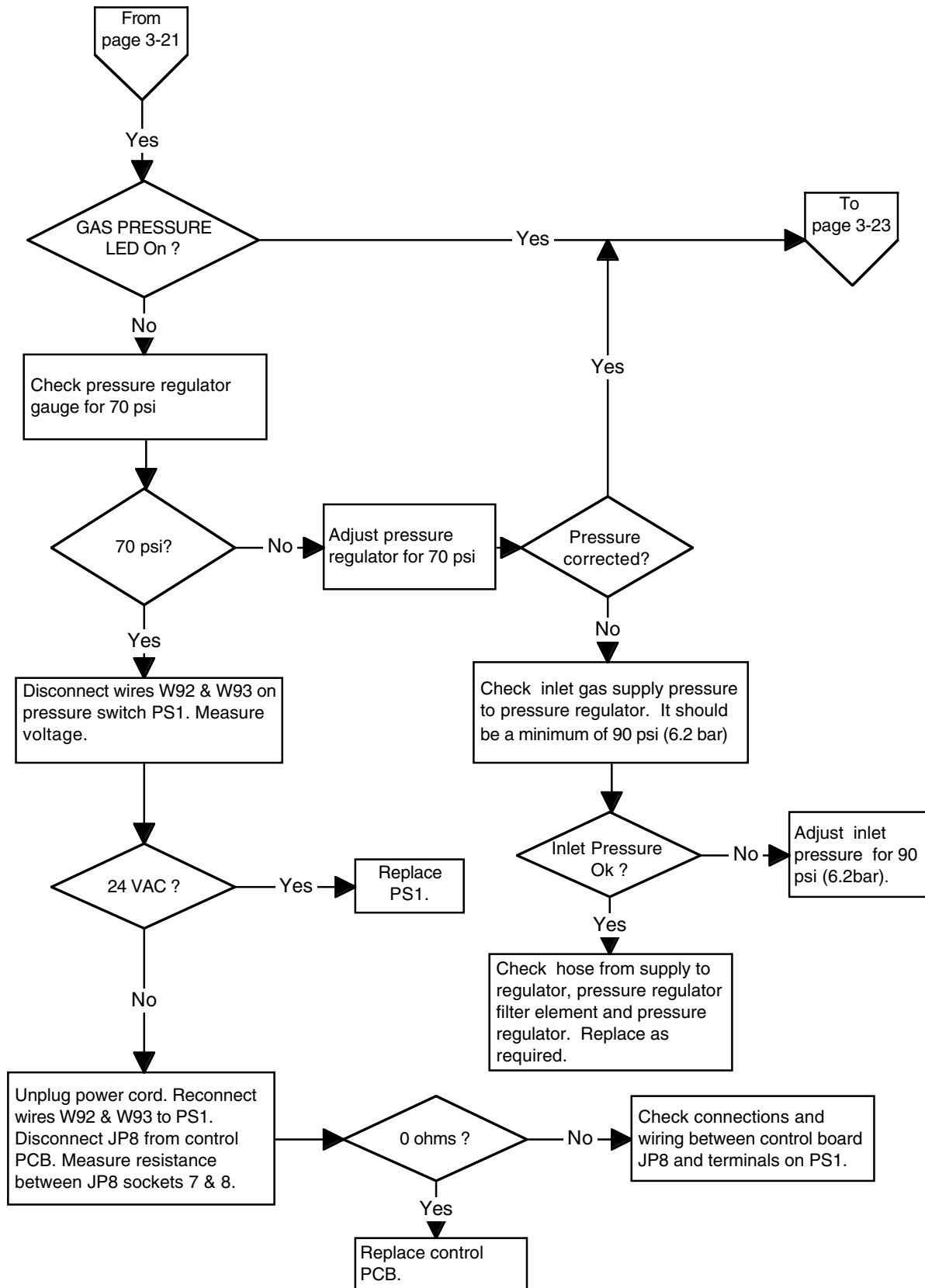

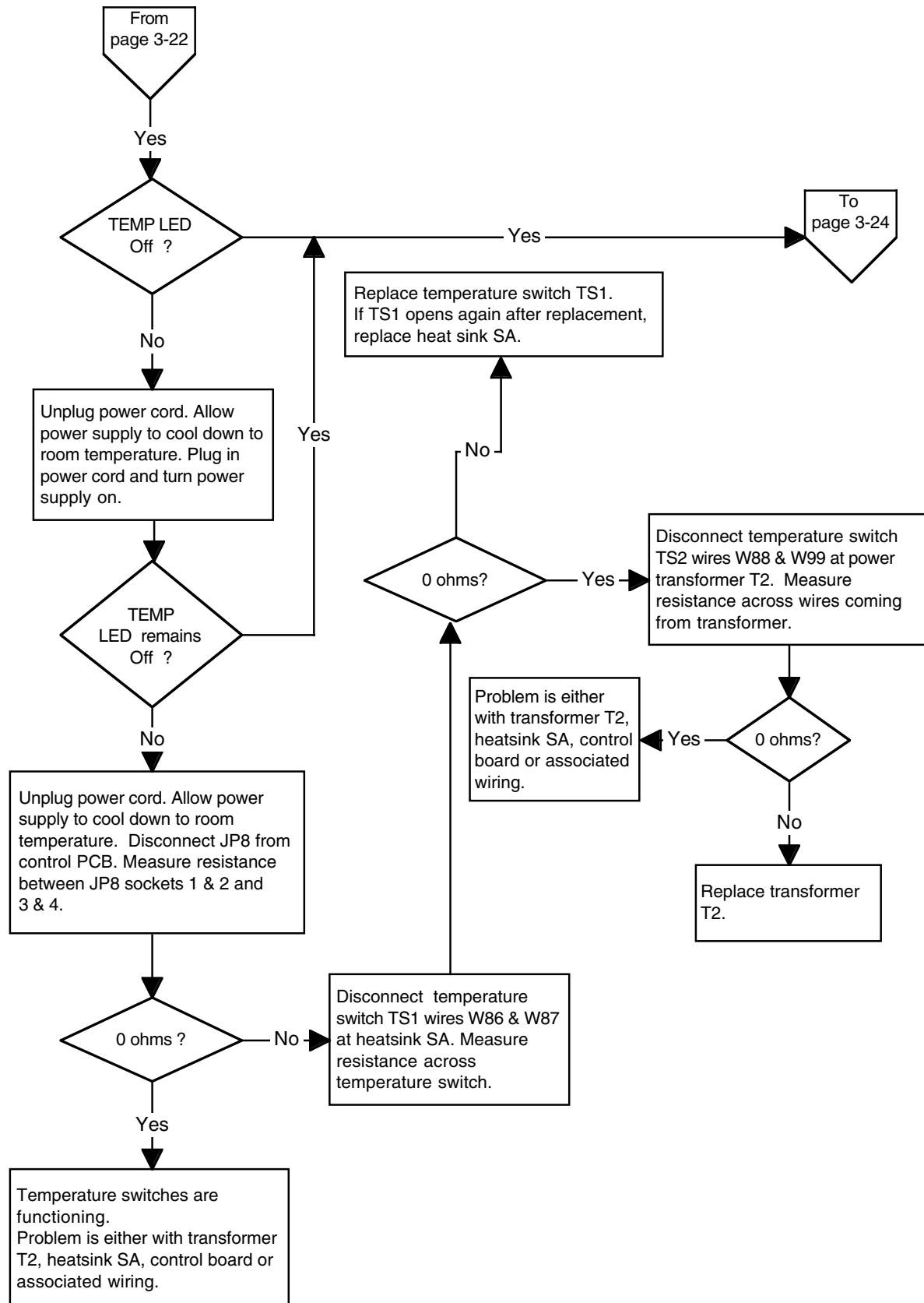

MAINTENANCE

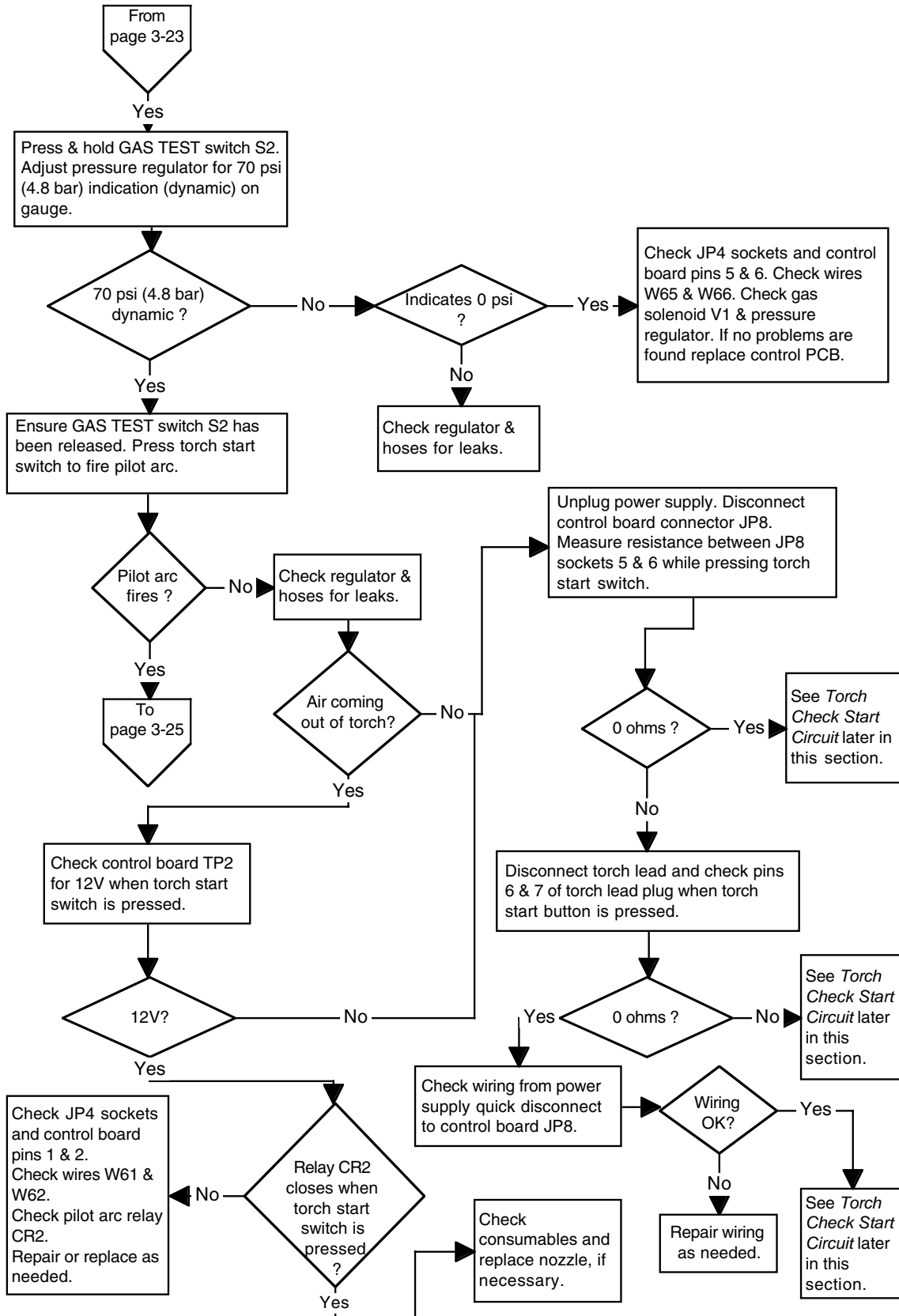

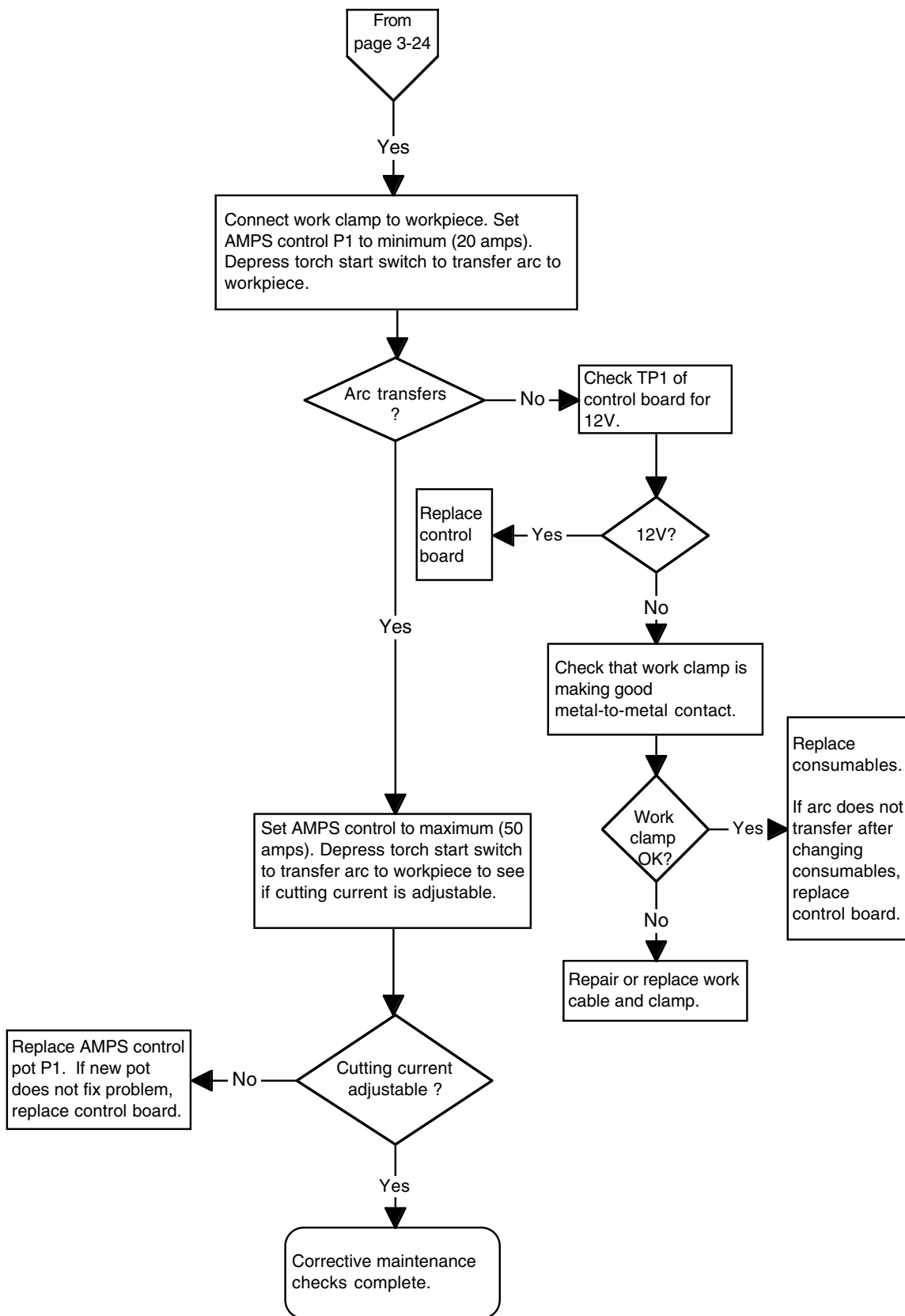

POWER BOARD

The power board contains part of a "soft start" or "in-rush" circuit, an over-voltage shut down circuit, and the high-voltage power circuits for left and right inverters. Voltages can be taken at the rear of the power PCB to check these functions.



WARNING



SHOCK HAZARD: The "E" terminals and J1 are accessible from the back side of the power PCB. Use extreme caution when taking these readings. Voltages up to 300 VDC are present at the rear of the power PCB.

The large electrolytic capacitors, (blue-cased cylinders) located on the front side of the power PC board store large amounts of energy in the form of electrical voltage. Even if the power is off, dangerous voltages exist at the capacitor terminals on the PC board and on certain areas of the PC board. Never discharge the capacitors with a screwdriver or other implement... explosion, property damage and/or personal injury will result.

Wait at least 5 minutes after turning the power supply off before handling the PC board or capacitors. If questions or problems arise during servicing, call Hypertherm Technical Services at 1-800-643-9878.

Use extreme caution when taking the voltage readings on the back of the power PCB - see warning above. Use an isolated or "floating" digital volt meter, since high voltages are present. The following table lists the test points, their descriptions and values. Refer also to Figure 3-5 to locate test points.

Power Board Test Points

Test Point	Description	Value
E1 to E3	High-voltage power - Left Inverter	+300VDC
E14 to E3	One-half of High-voltage power - Left Inverter	+150VDC
E4 to E5	High-voltage power - Right Inverter	+300VDC
E15 to E5	One-half of High-voltage power - Right Inverter	+150VDC
J1-5 to J1-4	"Soft start" signal from control PCB. After incoming voltage is accepted by control board, control board sends +12VDC to relay RL1 on power board. LINE VOLTAGE LED will remain lit until "soft start" signal is complete (about 5 seconds after S1 is thrown).	+12VDC 5 sec. after throwing power switch S1.
J1-6 to J1-4	Shut down signal from power board. Protection circuit on power board will go low (\approx 0 VDC) to control board to shut down power supply if it detects over voltage.	+12 VDC normally. \approx 0 VDC if voltage too high.



WARNING



SHOCK HAZARD: Do not attempt repairs on the power board or control board. Do not in any way cut away or remove the protective conformal coating from either board. To do so will risk a short between the AC input circuit to the output circuit and may cause serious injury or death.

The power supply and PC boards are subjected to dielectric and insulation resistance tests per applicable CSA and IEC standards for the safety of the operator and service technicians.

Removal of the protective conformal coatings and other unauthorized repairs to the PC boards will void the warranty.

If questions or problems arise during servicing, call the Hypertherm Technical Services department at 1-800-643-9878.

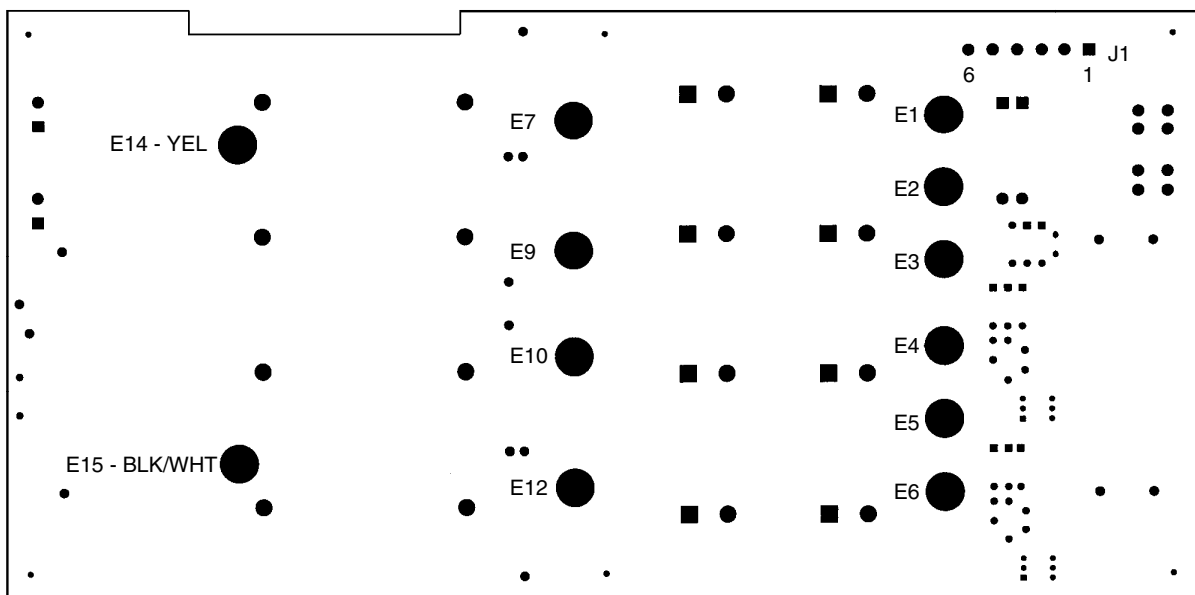

Figure 3-5 Back Side of Power Board - Test Points

CONTROL BOARD

Control Board LEDs

There are 4 control board LEDs visible from the Powermax800 front panel. There are 6 more LEDs that are visible only when the cover is removed. See Figure 3-6 for location of LEDs.

- **D8 POWER ON:** Illuminates when power is applied.
- **D15 LINE VOLTAGE:** Illuminates when the input voltage is out of limits. This LED will remain on if the line voltage is too low, and go on briefly before the power supply shuts down if the line voltage is too high.

Note: LINE VOLTAGE LED always remains on for about 5 seconds after the power supply is turned on and before a "soft start" signal is sent from the control board to the power board. The upper and lower range for line voltages are as follows:

Lower Limit	Line Voltage	Upper Limit	
170VAC	200VAC	235VAC	Note: To avoid performance deterioration of the Powermax800, input voltage should be within 10% of the specified system line voltage setting.
178VAC	208VAC	239VAC	
195VAC	230VAC	270VAC	
204VAC	240VAC	276VAC	
340VAC	400VAC	470VAC	
408VAC	480VAC	552VAC	
510VAC	600VAC	690VAC	

- **D24 OVERCURRENT:** Illuminates when CS1 or CS2 senses current above 70 amps.
- **D25 PILOT ARC RELAY:** Illuminates when pilot arc relay CR2 is energized.
- **D26 GAS SOLENOID:** Illuminates when gas solenoid is energized (when GAS TEST switch is pressed or when plasma start is pressed).
- **D27 MAIN CONTACTOR:** Illuminates when contactor CR1 is energized (following "soft start").
- **D29 TEMP LED:** Remains off when temperature is within operating limits. It Illuminates when the thermostat in the power transformer opens (over 110° C (230° F)) or if the heatsink becomes too hot (over 85°C (185° F)). Overheating can be caused by exceeding the duty cycle rate.
- **D35 GAS PRESSURE:** Illuminates when incoming gas pressure sensed by PS1 is within operating limits (over 39 psi (2.7 bar)).
- **D38 ARC TRANSFER:** Illuminates when arc transfers to the workpiece.
- **D42 PLASMA START:** Illuminates when the torch start button is pushed or when start button is activated from the machine interface.

The control board also controls the sequence required to generate plasma:

- Turns on the inverter when the torch switch button is pressed
- After a short delay, turns on the gas solenoid valve V1 to blow back the electrode
- Monitors the pilot arc for arc transfer
- Ramps the current control command from the pilot arc level (20 amps) to the cut current selected by the operator
- Turns the inverter off if the arc transfer does not occur within 5 seconds
- Turns the power supply off when the retaining cap is loose or when line voltage is too high

Control Board Test Points

Test Point	Description	Value
TP1	Transfer signal.	A logic high (12V) indicates that the arc is transferred.
TP2	Start signal.	A logic high (12V) indicates that the torch start switch is on.
TP3	GND	
TP4		+12V
TP5	Unregulated DC voltage.	Approximately 30VDC at nominal input voltage.
TP6		+18V
TP7	INV-ON signal.	A logic high (12V) indicates that the inverter is on.
TP8	Transfer latch signal.	A logic high (12V) indicates that unit is in transferred mode.
TP9	Temp OK signal.	A logic high (12V) indicates that all temperatures are OK.
TP10	Continuous PA threshold voltage.	Set to 3.55V by P3.
TP11		7.0V
TP15	Error amplifier reference voltage.	During inverter operation this signal is 1.915V at 50A current setting and .75V at 20A current setting.
TP16	Error amplifier output voltage	
TP17	Reference voltage	2.50V
TP18	Output current value signal	38.3mv/amp
TP19	Wiper voltage.	2.5V at 50A current setting and 1.00V at 20A current setting.
TP20	GND	
TP21	Buffered, inverted, capacitor feed version of pulse width modulator B signal.	
TP22	Buffered, inverted version of pulse width modulator A signal.	
Fuses		
F1,F2	Cap sensor circuit protection	.5A (see Parts List for part number and specifications)
F3,F4	Start circuit protection	.5A (see Parts List for part number and specifications)

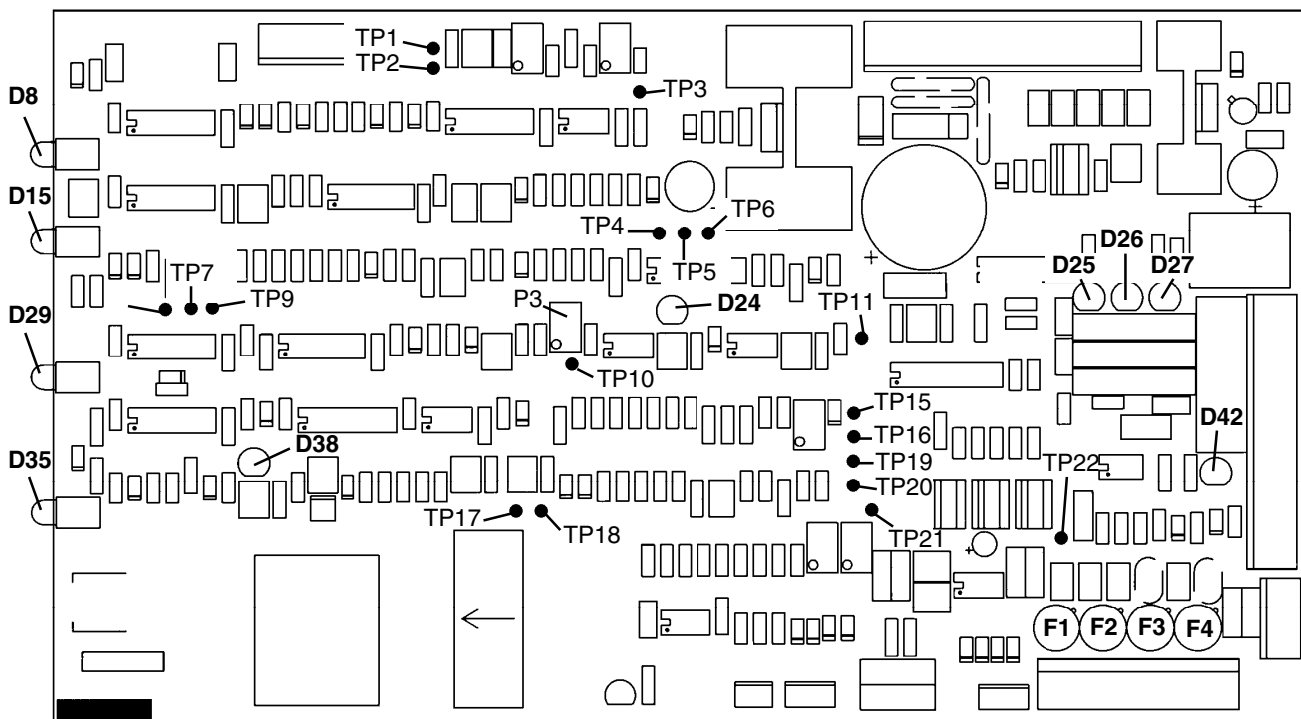

Figure 3-6 Control Board Test Points and LED Locations

MAINTENANCE

TORCH CHECK

A failure of the torch cap sensor circuit will cause the Powermax800 power supply to shut down, and a failure of the torch start circuit will prevent the torch from firing. If your Powermax800 has either of these problems and you have followed the *Corrective Maintenance Checks* beginning on page 3-17, proceed with the following checks.

Cap Sensor Circuit Check

If the torch retaining cap is screwed down tightly and the ON/OFF power switch shuts off, there could be a problem with the torch cap sensor circuit.



WARNING



Set the Powermax800 power switch to O (off), unplug the power cable, and disconnect the gas supply. Always wait 5 minutes before removing any cover of the power supply.

1. Disconnect power and gas. See warning above.
2. Remove the power supply cover.
3. Locate fuses F1 and F2 on the control board. See Fig. 3-6.
4. Check to see if the fuses are open.

If the fuses are open, replace the torch, the torch leads and the control board fuse(s). See **Section 4: Parts List** or **Section 5: Parts List - CE** to order new components.

If the fuses are OK, the retaining cap microswitch is working, the line voltage is OK, and the power supply continues to shut off, replace the control board.

TORCH CHECK (cont.)

Start Circuit Check

If the torch start trigger is pressed and there is no pilot arc, there could be a problem with the torch start circuit.



WARNING



Set the Powermax800 power switch to O (off), unplug the power cable, and disconnect the gas supply. Always wait 5 minutes before removing any cover of the power supply.

1. Disconnect power and gas. See warning above.
2. Remove the power supply cover.
3. Locate fuses F3 and F4 on the control board. See Fig. 3-6.
4. Check to see if the fuses are open.

If the fuses are open, replace the torch, the torch leads and the control board fuse(s). See **Section 4: Parts List** or **Section 5: Parts List - CE** to order new components.

If the fuses are OK, the gas supply is OK, pressing the torch switch closes the connection between JP8 sockets 5 & 6, and the torch does not start, replace the control board.

If the fuses are OK, the gas supply is OK, pressing the torch switch does not close connection between JP8 sockets 5 & 6, and the torch does not start, replace the torch and the torch leads.

PAC121TS TORCH PARTS REMOVAL AND REPLACEMENT

Torch Main Body Removal and Replacement

To remove and replace the torch main body, order the torch main body with cap-on sensor switch and refer to the following procedure and Figures 3-7 and 3-8.

1. **Set the Powermax800 power switch to O (off), unplug the power cable, and disconnect the gas supply. Disconnect the torch lead quick disconnect from the power supply.**
2. Remove the five screws that secure the handle halves together and remove handles from torch main body, torch switch and safety trigger (Fig. 3-8).
3. Remove the red wires attached to the pilot arc tab (Fig. 3-7).

Note for step 4: Disconnect wires by pulling on terminals. Do **not** pull on wires.

4. Disconnect the two lead terminals (blue wire in each terminal) from the two white wires of the cap sensor microswitch (Fig. 3-7).
5. Disconnect the plunger wire from the torch main body by holding the plunger nut with a 1/4" (6mm) wrench or nut driver and removing the plunger screw (Fig. 3-7).
6. Disconnect the torch main body and torch lead gas fittings using 5/16" (8mm) and 7/16" (11mm) open-end wrenches.
7. Replace with the new torch main body by reversing these instructions. Note: When connecting the plunger wire, be certain to keep the plunger wire terminal at the proper angle as shown in Fig. 3-7 inset. Tighten the plunger screw with 8 lb-in (9 kg-cm) of torque.
8. Install the torch main body and torch switch back into handle (Fig. 3-8). Be certain that torch switch slides into position above safety trigger, and that trigger movement activates the switch pushbutton and then releases. While positioning the handle halves together, be careful not to pinch any wires.
9. Replace the five screws to secure the handle halves together.

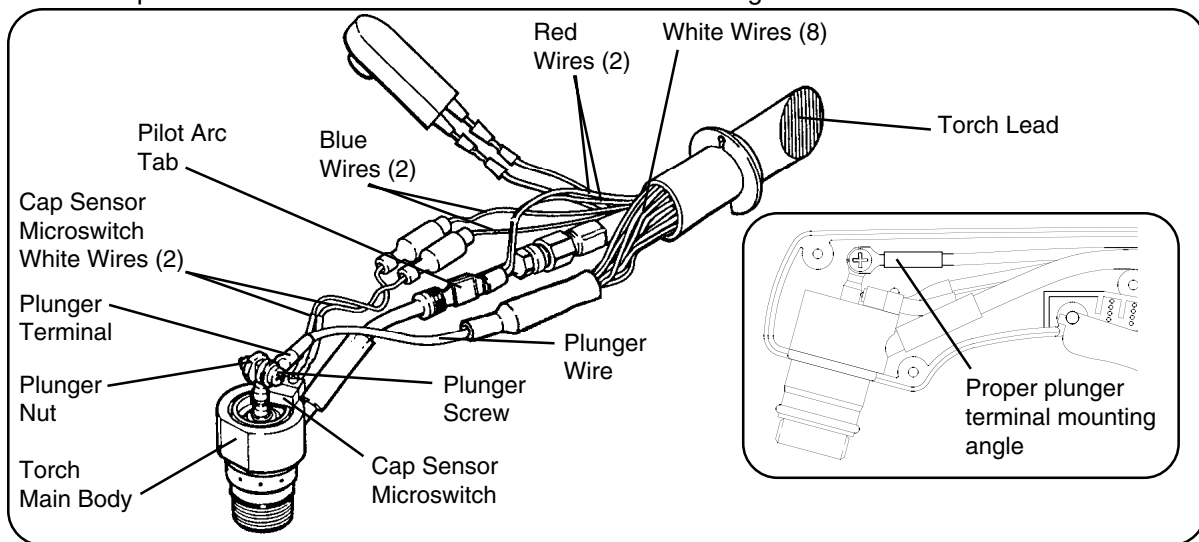

Figure 3-7 PAC121TS Torch Main Body Removal

Torch Switch Removal and Replacement

To remove and replace the torch switch, order the torch switch and two splices (074069) and refer to the following procedure and Figure 3-8. See page 4-10 for a complete torch parts list.

1. **Ensure the Powermax800 power switch is set to O (off), unplug the power cable, and disconnect the gas supply.**
2. Remove the five screws that secure the handle halves together.
3. Remove the torch switch from the handle.
4. Remove the torch switch by cutting the two splices at the torch lead (violet wires).
5. Replace the torch switch by crimping the switch wires and the violet wires from the torch lead together with the splices.
6. Install the torch switch back into handle. Be certain that torch switch slides into position above safety trigger, and that trigger movement activates the switch pushbutton and then releases. While positioning the handle halves together, be careful not to pinch any wires.
7. Replace the five screws to secure the handle halves together.

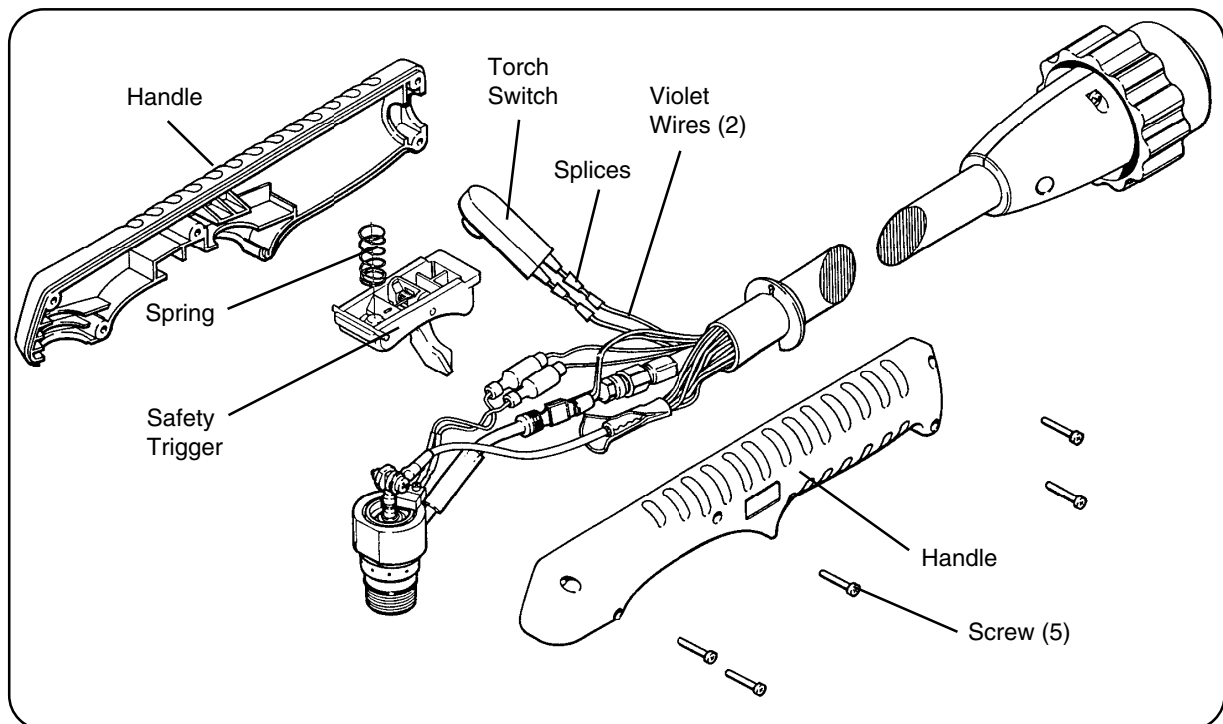

Figure 3-8 PAC121TS Torch Switch Removal

PAC121MS TORCH PARTS REMOVAL AND REPLACEMENT

Repair of the PAC121MS machine torch normally requires replacement of the torch main body and/or the torch lead. Order the torch main body with switch. Refer to Figure 3-9 and perform the steps below. See page 4-11 for a complete torch parts list.

Removal

1. **Set the Powermax800 power switch to O (off), unplug the power cable, and disconnect the gas supply. Disconnect the torch lead quick disconnect from the power supply.**
2. Unscrew the retaining cap and remove the remaining parts (nozzle, electrode and swirl ring).
3. Remove the O-ring from the torch main body.
4. Remove the three screws securing the torch sleeve to the torch main body.
5. Unscrew the torch position sleeve from the torch sleeve and slide it back out of the way.
6. Remove the screw securing the red wires from the torch lead to the torch main body.

Note for steps 7 and 8: Disconnect wires by pulling on terminals. Do **not** pull on wires.

7. Disconnect the two lead terminals (four white wires in each terminal) from the two black plunger wire terminals of the torch main body.
8. Disconnect the two lead terminals (blue wire in each terminal) from the two white wires of the cap sensor microswitch.
9. Disconnect the torch main body and torch lead gas fitting using the 5/16" (8 mm) and 7/16" (11 mm) open-end wrenches.

Replacement

1. Remove the O-ring from the replacement torch main body.

Caution: Use caution when removing the O-ring, it can easily be damaged.
--

2. Connect the torch main body to the torch lead gas fitting using open-end wrenches.
3. Connect the two lead terminals (blue wire in each terminal) to the two white wires of the cap sensor microswitch.
4. Connect the two lead terminals (four white wires in each terminal) to the two black plunger wires of the torch main body.

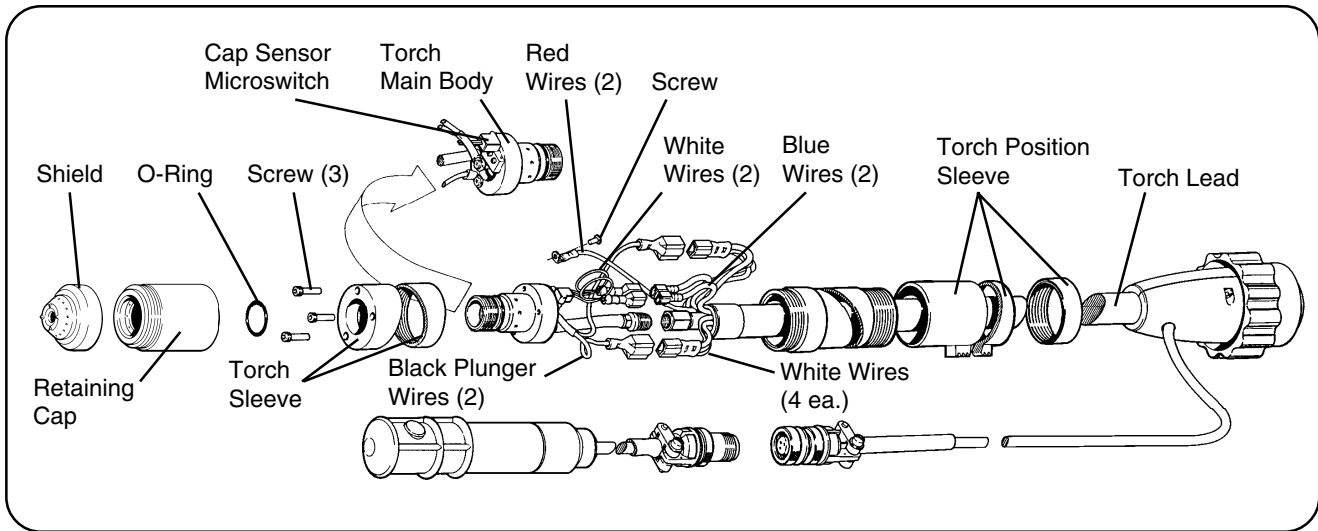

Figure 3-9 PAC121MS Torch Assembly

5. Secure the red wires from the torch lead to the torch main body with screw.
6. Position the torch sleeve onto the torch main body and secure it with the three screws.
7. Use caution when installing the O-ring onto the torch main body, it can be easily damaged. Lightly coat with silicone.
8. Screw the torch position sleeve and the torch sleeve together.
9. When the nozzle, electrode and swirl ring are properly in place, replace the retaining cap with shield. When the retaining cap is tightened, the microswitch will click, indicating that the torch main body has been replaced correctly.
10. Align the connector plug key (on torch lead) with the connector receptacle key slot (on power supply) and push it in until the pins seat.
11. Turn the connector securing ring 1/4 turn counterclockwise to ensure that the securing ring threads and the connector receptacle threads are aligned prior to tightening. Turn the connector securing ring clockwise to tighten.

QUICK DISCONNECT O-RING REMOVAL AND REPLACEMENT

The quick disconnect O-ring on the PAC121 torch leads provides a tight seal between the quick disconnect plug and the power supply receptacle. This O-ring prevents plasma gas from leaking during cutting. To remove and replace the O-ring in the event of damage or wear, proceed as follows and refer to Figure 3-10.

1. Turn the Powermax800 power switch OFF (0).
2. Unplug the power cable or set line disconnect switch to off, and disconnect gas supply.
3. Unscrew and remove the torch lead quick disconnect plug from the receptacle on the power supply.
4. Remove the O-ring from the quick disconnect as shown in Figure 3-10 using needle nose pliers, tweezers, etc.
5. Replace O-ring. Ensure it seats properly.

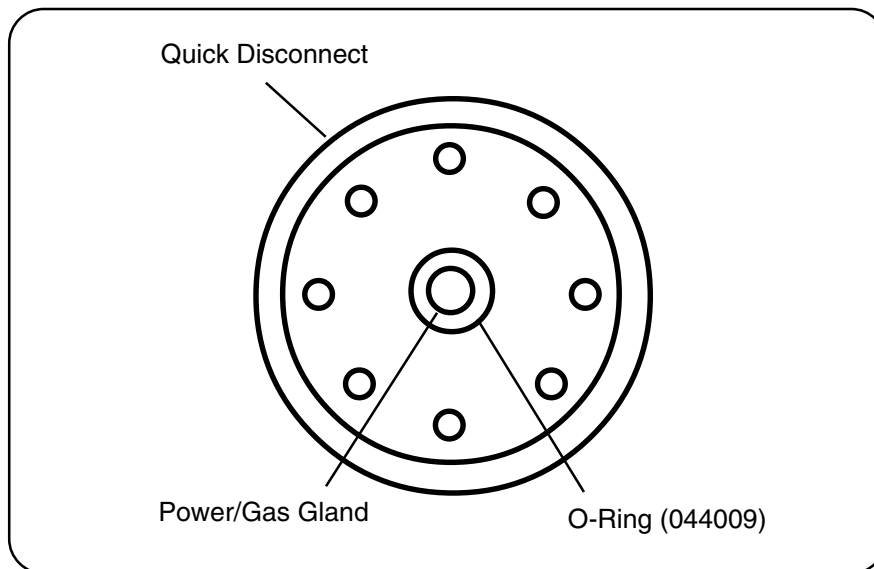

Figure 3-10 Quick Disconnect O-Ring Removal and Replacement

Section 4 PARTS LIST

In this section:

Power Supply - 208/240/480V	
200/230/400V	4-2
Front	4-2
Top and Right Side	4-4
Bottom and Left Side	4-6
Rear	4-8
PAC121TS Torch Assembly	4-10
PAC121MS Torch Assembly	4-11
Consumable Parts	4-12
Powermax800 Field Upgrade Kits and Optional Parts	4-13
Power Supplies - 208/240/480V	4-13
Power Supplies - 200/230/400V	4-13
Recommended Spare Parts - Powermax800 - 208/240/480V	4-14
Recommended Spare Parts - Powermax800 - 200/230/400V	4-14

PARTS LIST

POWER SUPPLY - 208/240/480V 200/230/400V

Note: See **Section 5 Parts List 400V CE** for parts and components of the 400V CE Powermax800 system.

Front

Index No.	Part No.	Description	Ref. Desig.	Quantity
1	001502	Pnl:PMX800 Pwr Unit Plastic Front		1
2	001522	Chassis:PMX800 Pwr Unit		1
3	004675	Spacer:PMX800 Pressure Gauge		1
4	008965	Knob:.850 Dia. 1/4 SFT Blk/Sil		1
4A	075498	Flat washer: .257 .500 .062 Black Nylon		1
5	010917	Label:PMX800 Pwr Unit Control Panel		1
6	023922	Cable w/Clamp:PMX800 Work 20'		1
7	008279	Strain Relief:PG9 X .187-.312 Nylon		1
	029955	Manifold SA:PMX800 Pwr Unit		1
8	005112	Pressure Switch:39 Psi .013 Orifice	PS1	1
9	006054	Sol. Valve:100# 1/8FPT 24VAC NC	V1	1
10	011073	Regulator:0-125 Psig 1/8FPT		1
11	011074	Nut:Regulator Panel Mounting		1
12	015282	Female Elbow:1/8NPTX1/4Push in tube		1
13	015283	Male Elbow:1/8NPX1/4Push in tube		1
14	015285	Male Conn.:1/8NPTX1/4Push in tube		3
15	015517	Nip:1/8 X CL Hex Brass		1
16	015540	Tee:1/8 Brass		1
17	015588	Nip:1/8 X 2"L Brass		1
18	022027	Press. Gauge:160# 1.5" 1/8CBM Panel		1
19	046077	Tubing:1/4"OD .04W Blue Nylon		2.3 ft
	029956	Harness:PMX800 Power Unit		1
20	009480	Pot:250-Ohm 1W 10% 1T Cerm	P1	1
21	029962	Recept. SA:PMX800 Pwr Unit Quick Disc.		1
22	004532	Locknut:42/43 Quick Disc. Recept.		1
23	008606	Socket:MS Cont		7
24	015282	Female Elbow:1/8NPTX1/4Push in tube		1
25	075362	Flat Washer:1/2 .500 1.50 .125 Nylon		1

Notes: **Bold** part numbers and descriptions are subassemblies.
Indented normal type items are components of subassemblies

All mounting hardware in power supply drawings shown for reference only.

**POWER SUPPLY - 208/240/480V
200/230/400V**

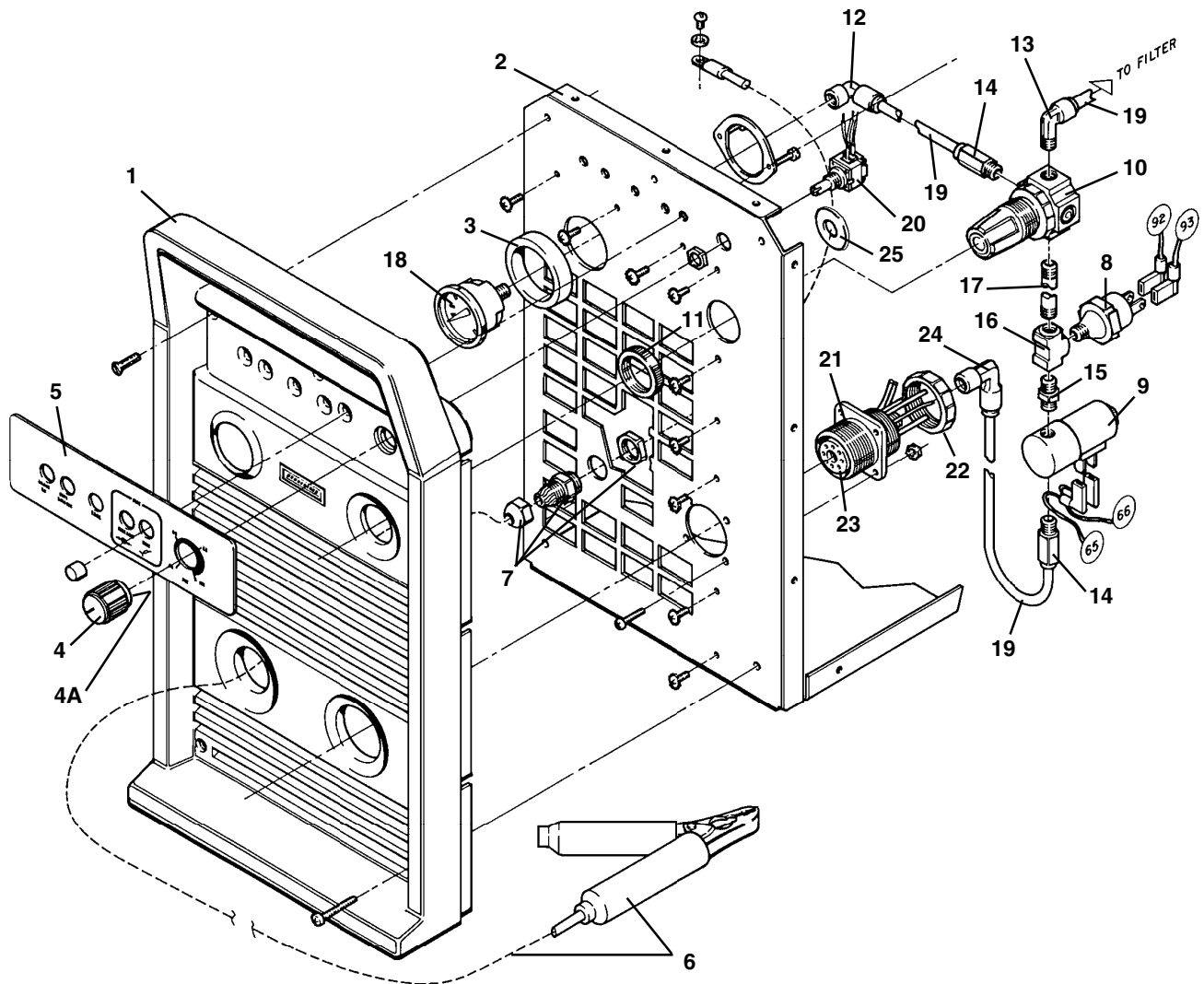

Figure 4-1 Powermax800 - Front

PARTS LIST

POWER SUPPLY - 208/240/480V 200/230/400V

Note: See Section 5 Parts List
400V CE for parts and
components of the 400V CE
Powermax800 system.

Top and Right Side

Index No.	Part No.	Description	Ref. Desig.	Quantity
1	001521	Pnl:Powermax800 Pwr Unit Center		1
2	003078	Relay:30A NO Mag Blwt QDisc Term	CR2	1
3	029674	MOV/Cap Assy:MAX42/43/70 3PH	MOV1	1
	029957	Heatsink SA:Powermax800 Power Unit		1
4	004721	Heatsink:Powermax800 Pwr Unit		1
5	008904	Thermal Pad:AL-340-180		1
6	008905	Thermal Pad:AL-370-134		2
7	008906	Thermal Pad:AL-380-100		2
8	009849	Resistor:20-Ohm 50W 5% NON-IND		4
9	009850	Resistor:20-Ohm 25W 5% NON-IND		4
10	009918	Capacitor:.012UF 1000WV 10% Poly		4
10A	009968	Capacitor:6800PF 1000WV 10% Poly		4
11	005178	Temp. Switch Opens 85°/Closes 75°C	TS1	1
12	029998†	IGBT Gate Drive SA:Powermax800	Q1	1
13	029998†	IGBT Gate Drive SA:Powermax800	Q2	1
14	109018†	Diode:600V 100A UFast Recovery Dual	D2	1
15	109018†	Diode:600V 100A UFast Recovery Dual	D3	1
16	109019†	Diode:1600V 100A 3PH Module	D1	1
17	041472***	PCB Assy:Pwrmx800 Control - 208/240/480V		1
	008989	Fuse:500ma 250V IEC 127-3 Fast	F1-F4 (pcb fuse)	4
17	041517****	PCB Assy:Pwrmx800 Control - 200/230/400V	1	1
	008989	Fuse:500ma 250V IEC 127-3 Fast	F1-F4 (pcb fuse)	4
18	041532*****	PCB Assy:Powermax800-ZB Power		1
19	014137	Current Sense Transformer, 40A	CS1	1
20	014137	Current Sense Transformer, 40A	CS2	1
21	008301	Fuse Holder:2P 30A 13/32 X 1-1/2		1
22	008809***	Fuse:1A 600V 13/32 X 1-1/2 Slo	F1,F2	2
22	008958****	Fuse:1A 500V 10mmX38mm Slo	F1,F2	2
	029978*	Heatsink SA:Powermax800 PA Cont PCB	Q3	
23	004673*	Heatsink:Powermax800 PA Cont		
24	008905*	Thermal Pad:AL-370-134		
25	109020†*	Diode:600V 100A Fast IGBT Module		
26	041486*	PCB Assy:Powermax800 PA Cont		
	028905**	Kit:Powermax800 Machine Interface 208/240/480V		
	128035**	Kit:Powermax800 Machine Interface 200/230/400V		
27	041494**	PCB Assy:Powermax800 Machine Interface		

Notes: **Bold** part numbers and descriptions are subassemblies.
 Indented normal type items are components of subassemblies.
 All mounting hardware in power supply drawings shown for reference only.

† Order corresponding thermal pads when ordering these items

* Available only on power supplies with the pilot arc control option

** Available only on power supplies with the machine interface option

*** Used only on 208/240/480V power supplies

**** Used only on 200/230/400V power supplies

***** For power supplies with serial numbers before 800-010000, order 128108 power board kit to replace power board.

**POWER SUPPLY - 208/240/480V
200/230/400V**

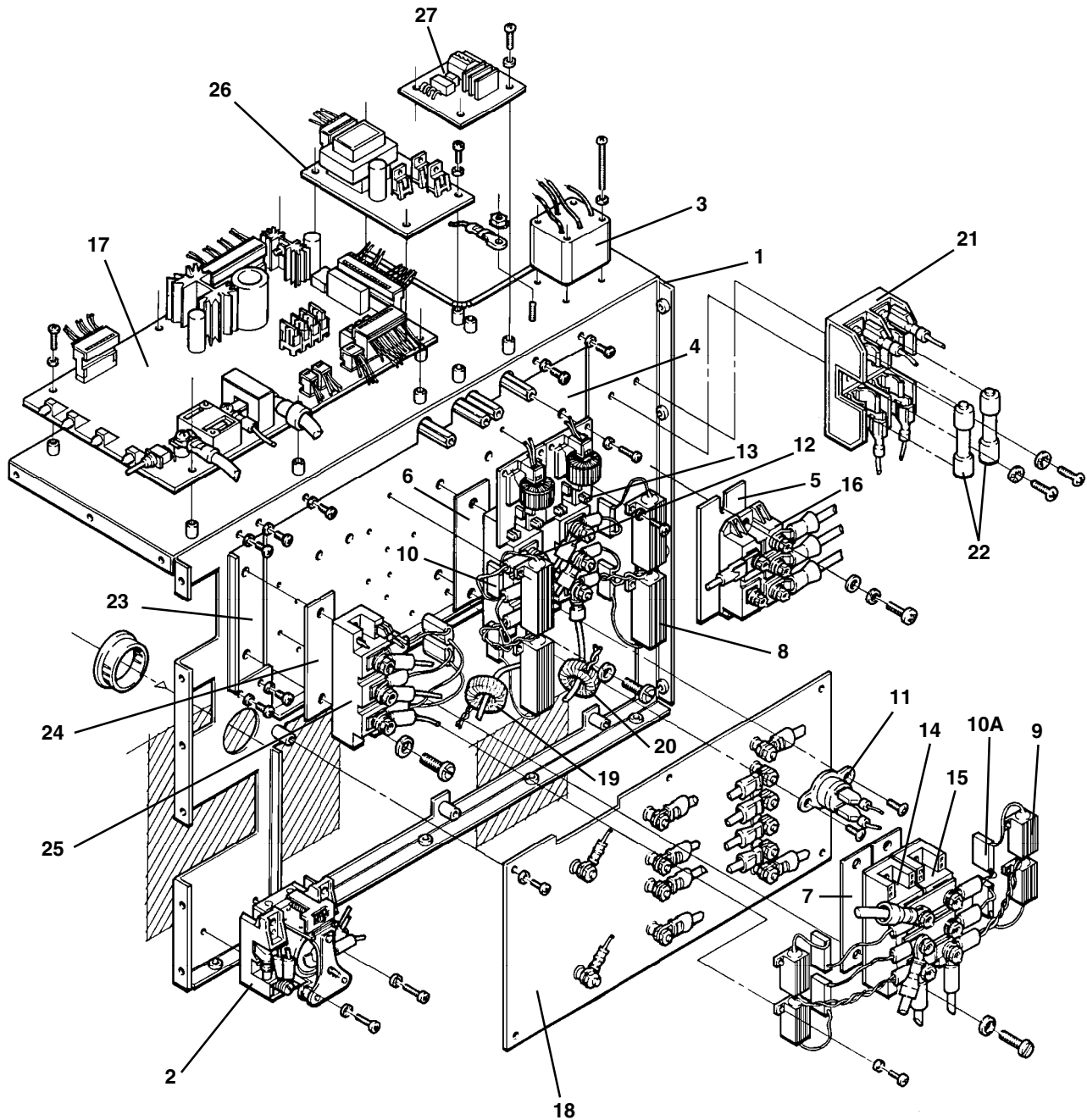

Figure 4-2 Powermax800 - Top and Right Side

PARTS LIST

POWER SUPPLY - 208/240/480V 200/230/400V

Note: See **Section 5 Parts List 400V CE** for parts and components of the 400V CE Powermax800 system.

Bottom and Left Side

Index No.	Part No.	Description	Ref. Desig.	Quantity
1	001521	Panel:Powermax800 Pwr Unit Center		1
2	001522	Chassis:Powermax800 Pwr Unit		1
3	004667	Bracket:Powermax800 Pwr Unit Fan		1
4	014207***	Xfmr:Powermax800 208-240-480 Control	T1	1
4	014208****	Xfmr:Powermax800 200-230-400 Control	T1	1
5	014210***	Xfmr:Powermax800 208-240-480 Power	T2 (w/TS2)	1
5	014211****	Xfmr:Powermax800 200-230-400 Power	T2 (w/TS2)	1
6	014186	Inductor:Powermax800 2MH 50A	L1	1
7	027080***	Fan:225CFM 120VAC 50-60HZ	M1	1
7	027443****	Fan:260CDM 120VAC 50-60HZ	M1	1
	029957	Heatsink SA:Powermax800 Power Unit		1
8	004721	Heatsink:Powermax800 Power Unit		1
9	041532*****	PCB Assy:Powermax800-ZB Power		1
	029978*	Heatsink SA:Pwrmx800 PA Cont PCB	Q3	
10	004673*	Heatsink:Powermax800 PA Cont		
11	028908**	Kit:Powermax800 Cooling Fan Filter		

Notes: **Bold** part numbers and descriptions are subassemblies.
Indented normal type items are components of subassemblies

All mounting hardware in power supply drawings shown for reference only.

* Available only on power supplies with the pilot arc control option

** Available only as an option

*** Used only on 208/240/480V power supplies

**** Used only on 200/230/400V power supplies

***** For power supplies with serial numbers before 800-010000, order 128108 power board kit to replace power board.

**POWER SUPPLY - 208/240/480V
200/230/400V**

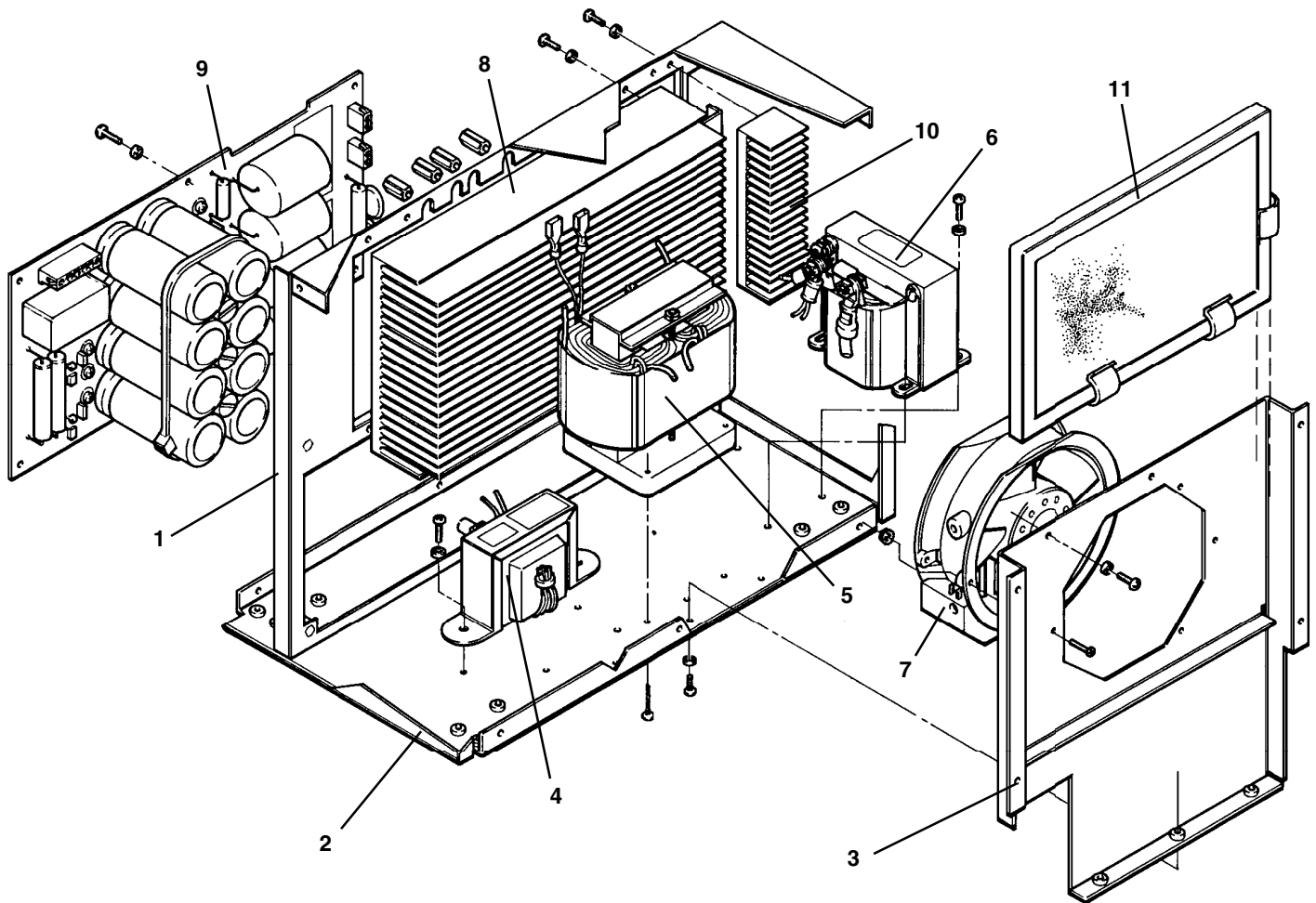

Figure 4-3 Powermax800 - Bottom and Left Side

PARTS LIST

POWER SUPPLY - 208/240/480V 200/230/400V

Note: See Section 5 Parts List
400V CE for parts and
components of the 400V CE
Powermax800 system.

Rear

Index No.	Part No.	Description	Ref. Desig.	Quantity
1	001503	Pnl:Powermax800 Pwr Unit Plastic Rear		1
2	001522	Chassis:Powermax800 Pwr Unit		1
3	129068	Circuit Breaker SA:4Pole 480V W/TC	S1	1
4	129151	Contactora SA:Powermax800	CR1	1
	029955	Manifold SA:Powermax800 Pwr Unit		1
5	011072	Filter:20 Micron 1/8FPT		1
6	015285	Male Connector:1/8NPTX1/4Push in Tube		1
7	011079	Filter Element for 011072 Filter		1
	029964	Linecord Panel SA:Powermax800 208/240/480V		1
8	001506*	Panel:Powermax800 Power Cord		1
9	008228	Cord Grip:1NPT .690-.990 2Screws		1
10	129114****	Power Cord SA:Powermax800		1
	129055	Linecord Panel SA:Powermax800 200/230/400V		1
8	001506**	Panel:Powermax800 Power Cord		1
9	008228	Cord Grip:1NPT .690-.990 2Screws		1
10	129115*****	Power Cord SA:Powermax800 200V		1
	029982	Link Box SA:Powermax800 208/240/480V		1
	129058	Link Box SA:Powermax800 200/230/400V		1
11	001500	Box:Powermax800 Pwr Cord		1
12	008900	Terminal Board:4-Terminal with protector	TB3	1
13	008926	Terminal Board:4-Terminal with protector	TB2	1
14	008933	Terminal Board:3-Terminal with protector	TB1	1
15	008279***	Strain Relief:PG9/5X.187-.312 Nylon		1
16	123099***	Cable: Powermax800 Machine Interface		1
	008201***	Receptacle Shell: 17-14 Reverse Sex		1
	008186***	Socket:24-20 AWG Type III		1

Notes: **Bold** part numbers and descriptions are subassemblies.
Indented normal type items are components of subassemblies

All mounting hardware in power supply drawings shown for reference only.

* Use 129134 to order power cord rear panel for 208/240/480V power supplies if you have the machine interface option.

** Use 129135 to order power cord rear panel for 200/230/400V power supplies if you have the machine interface option.

*** Available only with the machine interface option.

**** Single-phase cord with plug used on 208/240/480V systems.

***** 200/230/400V Three-phase cord without plug (129115) not shown in Figure 4-4.

**POWER SUPPLY - 208/240/480V
200/230/400V**

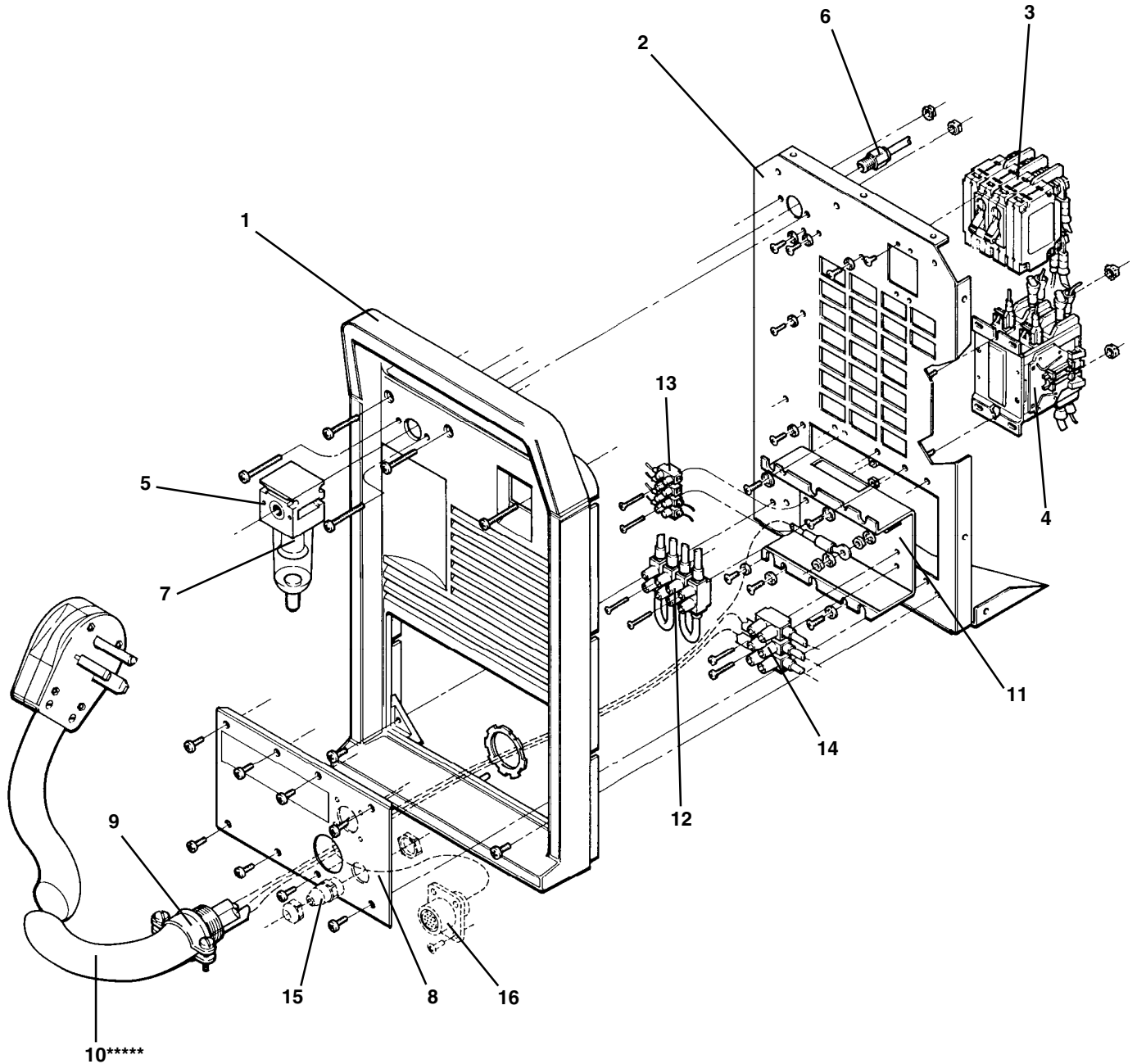

**** 200/230/400V Three-phase power cord not shown in Figure 4-4

Figure 4-4 Powermax800 - Rear

PARTS LIST

PAC121TS Torch Assembly and 25' (7.6 m) Lead - 083003 PAC121TS Torch Assembly and 50' (15.2 m) Lead - 083004

Part Number	Description
001288	Handle, PAC121T
002244	Safety Trigger, PAC121T
005094	Switch, Torch Pushbutton
020351	Electrode, Air
020361	Ring, Swirl
027254	Trigger Spring, PAC 121T
027466	Ring, Gutcha
075340	Screws, P/S, # 4 x 5/8, PH, RND, S/B
120282	Nozzle:PAC121 50A Shield
120283	Shield:PAC121 50A
120301	Cap, Retaining
120556	Torch Main Body w/Switch, PAC121T
044016	O-Ring:BUNA 90Duro .614X.070
129001*	Torch Lead, 25 ft. (7.6 m)
129002**	Torch Lead, 50 ft. (15.2 m)
044009	Quick Disconnect O-Ring (not shown)

* Used only in 083003

** Used only in 083004

Note: See page 4-12 for detail of consumable parts

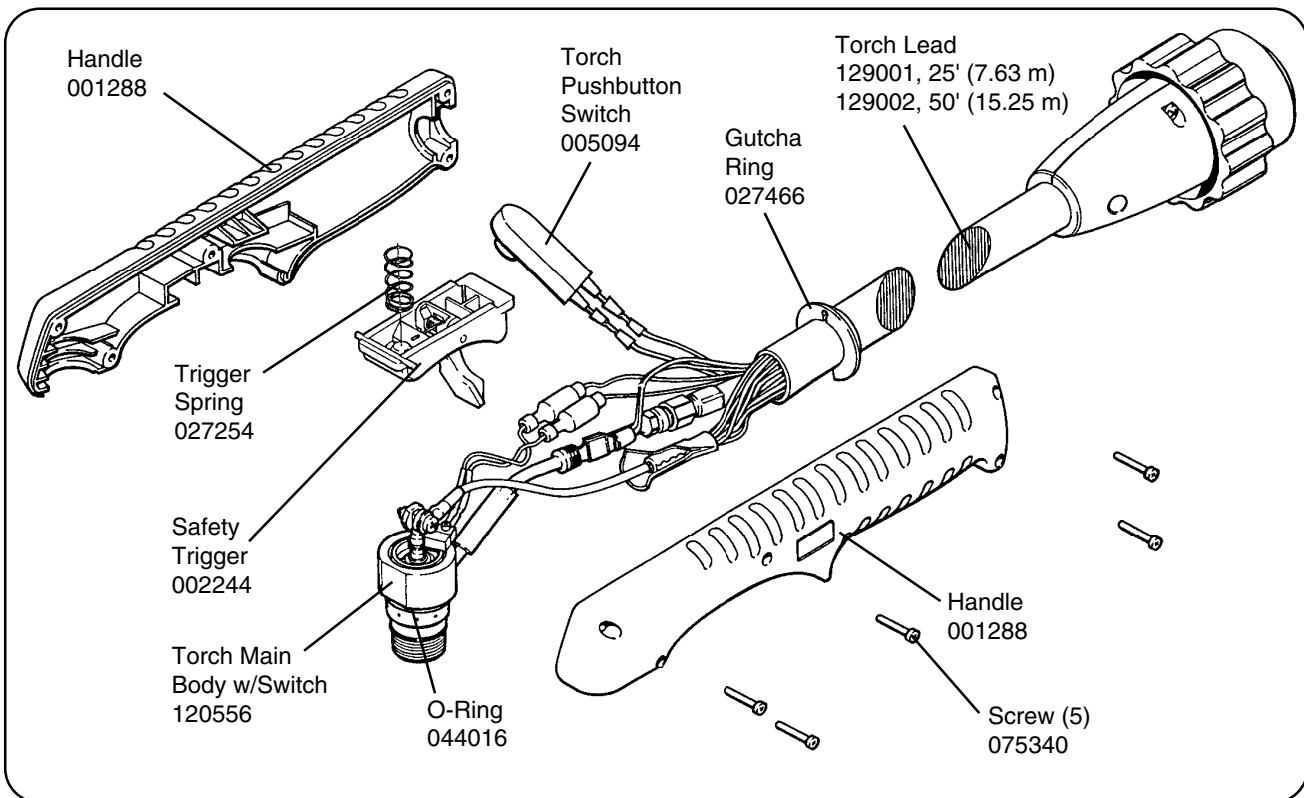

Figure 4-5 PAC121TS Torch Assembly and Leads

PARTS LIST

PAC121MS Torch Assembly and 14 ft (4.3 m) Lead - 083049 w/pigtail, 083054 no pigtail
PAC121MS Torch Assembly and 25 ft (7.6 m) Lead - 083011 w/pigtail, 083056 no pigtail
PAC121MS Torch Assembly and 35 ft (10.6 m) Lead - 083044 w/pigtail, 083057 no pigtail
PAC121MS Torch Assembly and 50 ft (15.2 m) Lead - 083012 w/pigtail, 083058 no pigtail

Part Number	Description
020351	Electrode
020361	Ring, Swirl
020559	Sleeve, Machine Torch, PAC121M
020620	Sleeve, Torch Position, PAC121M
028923	Torch Lead w/pigtail, 14 ft (4.3 m)
028918	Torch Lead w/pigtail, 25 ft (7.6 m)
028926	Torch Lead w/pigtail, 35 ft (10.6 m)
028919	Torch Lead w/pigtail, 50 ft (15.2 m)
128123	Torch Lead, no pigtail, 14 ft (4.3 m)
128125	Torch Lead, no pigtail, 25 ft (7.6 m)
128126	Torch Lead, no pigtail, 35 ft (10.6 m)
128127	Torch Lead, no pigtail, 50 ft (15.2 m)
044009	Quick Disconnect O-Ring (not shown)
075321	Socket Cap, 4-40 X 1/2, HX, SS
075322	M/S, 4-40 X 1/4, SL, SZ
120282	Nozzle: PAC121 50A Shield
120326	Shield: PAC121M Machine Torch
120301	Cap, Retaining
120558	Torch Main Body w/ Switch, PAC121M
044016	O-Ring: BUNA 90 Duro .614X.070

Note: See page 4-12 for detail of consumable parts

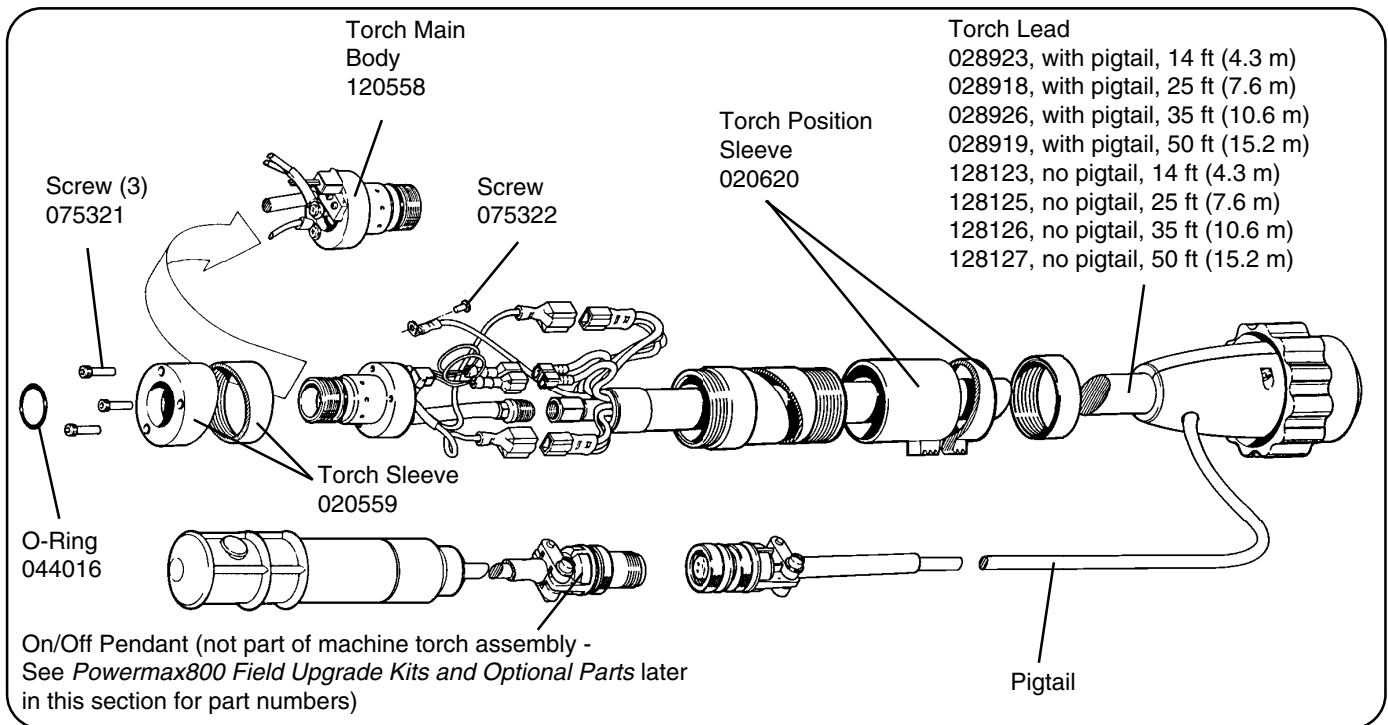

Figure 5-8 PAC121MS Torch Assembly and Leads

PARTS LIST

CONSUMABLE PARTS

Note: See Section 5 Parts List 400V CE for parts and components of the 400V CE Powermax800 system.

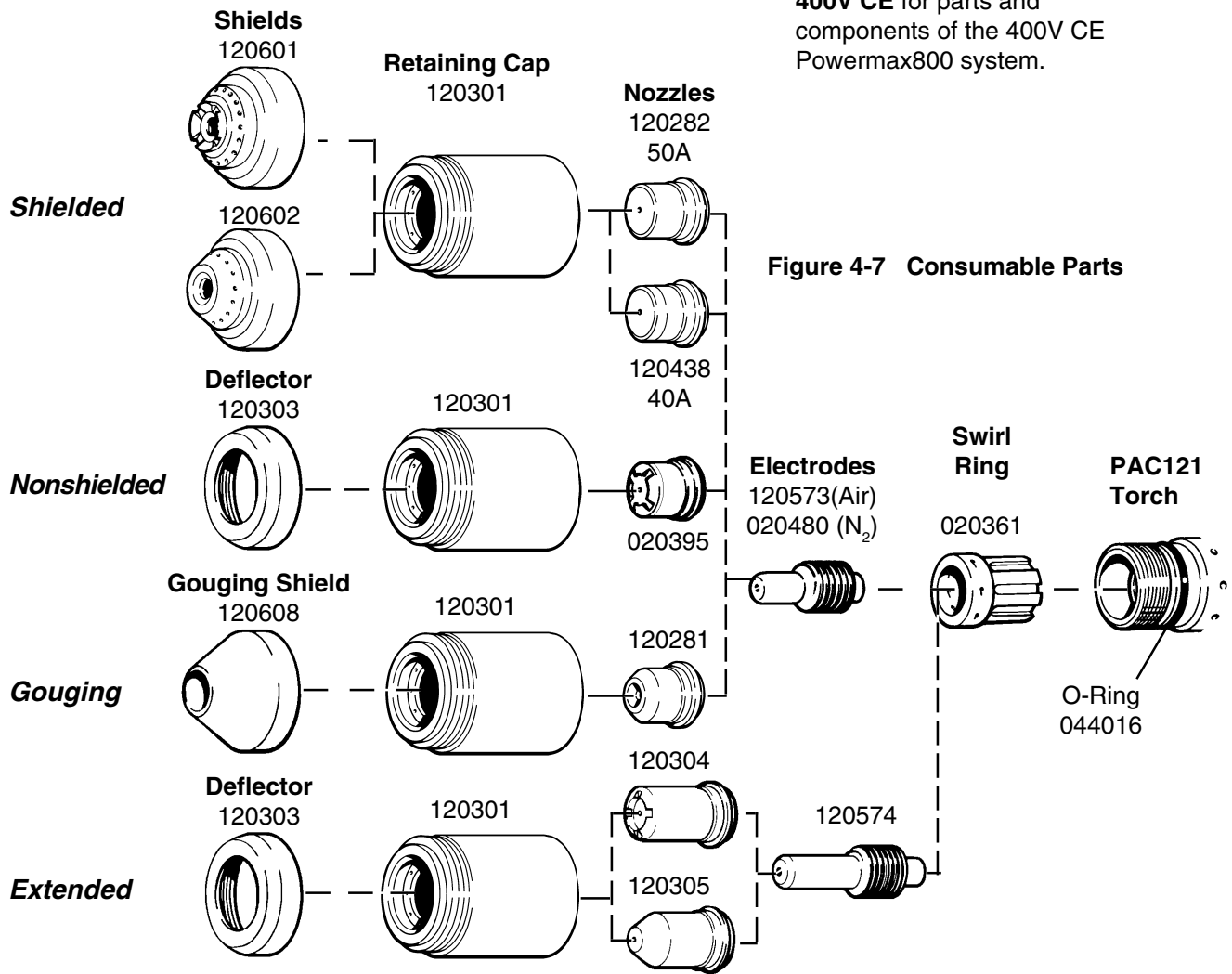

Figure 4-7 Consumable Parts

Consumable Spare Parts Kit (028904)		Mach. Consumable Spare Parts Kit (128030)	
Part Number	Description (Qty.)	Part Number	Description (Qty.)
001285	Box, Consumable Parts (1)	001285	Box, Consumable Parts (1)
120573	Electrode (3)	120573	Electrode, (4)
120574	Electrode, Extended (1)	120574	Electrode, Extended (2)
120282	Nozzle, 50A, Shielded (3)	120282	Nozzle, 50A, Shielded (2)
120281	Nozzle, 50A, Gouging (1)	120438	Nozzle, 40A, Shielded (2)
120305	Nozzle, Pipe Saddle, Extended (1)	120305	Nozzle, Pipe Saddle, Extended (2)
120601	Shield, T torch, (1)	120602	Shield, M torch (1)
120608	Shield, Gouging (1)	120303	Deflector (1)
120303	Deflector (1)	044016	O-Ring (3)
044016	O-Ring (3)	015152	Nipple, 1/8 NPT, QDisc, Steel (1)
015152	Nipple, 1/8 NPT, QDisc, Steel (1)	015570	Bushing, Reducer, 1/4 X 1/8, Brass (1)
015570	Bushing, Reducer, 1/4 X 1/8, Brass (1)	015604	Reducer, 1/4 FPT X 1/8 NPT, Brass (1)
015604	Reducer, 1/4 FPT X 1/8 NPT, Brass (1)	027055	Lubricant, Silicone 1/4 Oz Tube (1)
027055	Lubricant, Silicone 1/4 Oz Tube (1)		

POWERMAX800 FIELD UPGRADE KITS AND OPTIONAL PARTS

Part Number	Description
028714	On/Off Pendant w/Lead, 25 ft. (7.6 m) (Also comes standard with most machine torch system configurations. See note below.)
128061	On/Off Pendant w/Lead, 50 ft. (15.2 m)
128062	On/Off Pendant w/Lead, 75 ft. (23 m)
028864	Kit: Powermax800 Pwr Unit Wheels
028898	Pilot Arc Controller Kit
028905	Machine Interface Kit, 208/240/480V
128035	Machine Interface Kit, 200/230/400V
028907	Work Cable, 50' (15.2 m)
028908	Cooling Fan Filter Kit:Powermax800
011079	Gas Filter Element
129019	Jumper:Powermax800 Link Box
128032	Kit: Powermax800 600V
008809	Fuse:1A 600V 13/32 X 1-1/2 Slo (Used on 208/240/480V power supplies)
008958	Fuse:1A 500V 10mm X 38mm Slo (Used on 200/230/400V and 400V CE power supplies)
023206	Cable: Machine Interface, 25 ft (7.6 m) (Comes standard with machine torch system configurations and with machine interface kits.)

POWER SUPPLIES - 208/240/480V, 1 ϕ /3 ϕ , 60 HZ

Part Number	For Torch Type	With Pilot Arc Control	With Machine Interface
083002	Hand	No	No
083015	Hand	Yes	No
083016	Machine	No	Yes
083017	Machine	Yes	Yes

POWER SUPPLIES - 200/230/400V, 1 ϕ /3 ϕ , 50/60 HZ

Part Number	For Torch Type	With Pilot Arc Control	With Machine Interface
083030	Hand	No	No
083033	Hand	Yes	No
083036	Machine	No	Yes
083039	Machine	Yes	Yes

Notes: Contact your distributor or call the nearest Hypertherm office for hand and machine torch system configurations.

See **Section 5 Parts List 400V CE** for parts and components of the 400V CE Powermax800 system.

PARTS LIST

RECOMMENDED SPARE PARTS - POWERMAX800- 208/240/480V

Part Number	Description	Page Reference
003078	Relay:30A NO Mag Blwt QDisc Term	4-5
129068	Circuit Breaker SA:4Pole 480V W/TC	4-9
129151	Contactora SA:Powermax800	4-9
008809	Fuse:1A 600V 13/32X1-1/2Slo (2)	4-4
014207	Xfmr:Powermax800 208-240-480 Control	4-7
014210	Xfmr:Powermax800 208-240-480 Power	4-7
014186	Inductor:Powermax800 2MH 50A	4-7
023922	Cable w/Clamp:PMX800 Work 20'	4-3
027080	Fan:225CFM 120VAC 50-60HZ	4-7
005112	Pressure Switch:39 Psi .013 Orifice	4-3
006054	Sol. Valve:100# 1/8FPT 24VAC NC	4-3
011072	Filter:20 Micron 1/8FPT	4-9
011079	Filter Element for 011072 Filter	4-9
011073	Regulator:0-125 Psig 1/8FPT	4-3
022027	Press. Gauge:160# 1.5" 1/8CBM Panel	4-3
029957	Heatsink SA:Powermax800 Power Unit	4-5
109018/008906	Diode:600V 100A UFast Recovery Dual (2)/Thermal Pad:AL-380-100 (2)	4-5
109019/008904	Diode:1600V 100A 3PH Module/Thermal Pad:AL-340-180	4-5
005178	Temp. Switch Opens 85°/Closes 75°C	4-5
009849/008903	Resistor:20-Ohm 50W 5% NON-IND (4)/Thermal Pad: AL 197-114 (4)	4-5
009850/008902	Resistor:20-Ohm 25W 5% NON-IND (4)/Thermal Pad:AL 103-108 (4)	4-5
009918	Capacitor:.012UF 1000WV 10% Poly (4)	4-5
009968	Capacitor:.6800PF 1000WV 10% Poly (4)	4-5
029998/008905	IGBT Gate Drive SA:Powermax800 (2)/Thermal Pad:AL-370-134 (2)	4-5
041472	PCB Assy:Powermax800 Control	4-5
041532	PCB Assy:Powermax800-ZB Power	4-5, 4-7
129114	Cord/Plug:42 1Phase 8-3SO 3Prong 7'3"	4-9
029674	MOV/Cap Assy:MAX42/43/70 3PH	4-5
028908	Kit:Powermax800 Cooling Fan Filter	4-7

RECOMMENDED SPARE PARTS - POWERMAX800- 200/230/400V

Part Number	Description	Page Reference
003078	Relay:30A NO Mag Blwt QDisc Term	4-5
129068	Circuit Breaker SA:4Pole 480V W/TC	4-9
129151	Contactora SA:Powermax800	4-9
008958	Fuse:1A 500V 10mmX38mm SLO (2)	4-4
014208	Xfmr:Powermax800 200-230-400 Control	4-7
014211	Xfmr:Powermax800 200-230-400 Power	4-7
014186	Inductor:Powermax800 2MH 50A	4-7
023922	Cable w/Clamp:PMX800 Work 20'	4-3
027443	Fan:260CDM 120VAC 50-60HZ	4-7
005112	Pressure Switch:39 Psi .013 Orifice	4-3
006054	Sol. Valve:100# 1/8FPT 24VAC NC	4-3
011072	Filter:20 Micron 1/8FPT	4-9
011079	Filter Element for 011072 Filter	4-9
011073	Regulator:0-125 Psig 1/8FPT	4-3
022027	Press. Gauge:160# 1.5" 1/8CBM Panel	4-3
029957	Heatsink SA:Powermax800 Power Unit	4-5
109018/008906	Diode:600V 100A UFast Recovery Dual (2)/Thermal Pad:AL-380-100 (2)	4-5
109019/008904	Diode:1600V 100A 3PH Module/Thermal Pad:AL-340-180	4-5
005178	Temp. Switch Opens 85°/Closes 75°C	4-5
009849/008903	Resistor:20-Ohm 50W 5% NON-IND (4)/Thermal Pad: AL 197-114 (4)	4-5
009850/008902	Resistor:20-Ohm 25W 5% NON-IND (4)/Thermal Pad:AL 103-108 (4)	4-5
009918	Capacitor:.012UF 1000WV 10% Poly (4)	4-5
009968	Capacitor:.6800PF 1000WV 10% Poly (4)	4-5
029998/008905	IGBT Gate Drive SA:Powermax800 (2)/Thermal Pad:AL-370-134 (2)	4-5
041517	PCB Assy:Powermax800 Control	4-5
041532	PCB Assy:Powermax800-ZB Power	4-5, 4-7
129115	Cord: 2.5mm PVC HD21/22	4-9
029674	MOV/Cap Assy:MAX42/43/70 3PH	4-5
028908	Kit:Powermax800 Cooling Fan Filter	4-7

Section 5 PARTS LIST - CE

In this section:

Power Supply - 400V CE	5-2
Front	5-2
Top and Right Side	5-4
Bottom and Left Side	5-6
Rear	5-8
PAC121TS Torch Assembly	5-10
PAC121MS Torch Assembly	5-11
Consumable Parts - CE	5-12
Powermax800 Field Upgrade Kits and Optional Parts	5-13
Power Supplies - 400V CE	5-13
Recommended Spare Parts - Powermax800 400V CE	5-14

PARTS LIST - CE

POWER SUPPLY - 400V CE

Note: See **Section 4 Parts List** for parts and components of the non-CE Powermax800 systems.

Front

Index No.	Part No.	Description	Ref. Desig.	Quantity
1	001502	Pnl:PMX800 Pwr Unit Plastic Front		1
2	001522	Chassis:PMX800 Pwr Unit		1
3	004675	Spacer:PMX800 Pressure Gauge		1
4	008965	Knob:.850 Dia. 1/4 SFT Blk/Sil		1
4A	075498	Flat washer: .257 .500 .062 Black Nylon		1
5	010917	Label:PMX800 Pwr Unit Control Panel		1
6	023922	Cable w/Clamp:PMX800 Work 20'		1
7	008279	Strain Relief:PG9 X .187-.312 Nylon		1
	029955	Manifold SA:PMX800 Pwr Unit		1
8	005112	Pressure Switch:39 Psi .013 Orifice	PS1	1
9	006054	Sol. Valve:100# 1/8FPT 24VAC NC	V1	1
10	011073	Regulator:0-125 Psig 1/8FPT		1
11	011074	Nut:Regulator Panel Mounting		1
12	015282	Female Elbow:1/8NPTX1/4Push in tube		1
13	015283	Male Elbow:1/8NPX1/4Push in tube		1
14	015285	Male Conn.:1/8NPTX1/4Push in tube		3
15	015517	Nip:1/8 X CL Hex Brass		1
16	015540	Tee:1/8 Brass		1
17	015588	Nip:1/8 X 2"L Brass		1
18	022027	Press. Gauge:160# 1.5" 1/8CBM Panel		1
19	046077	Tubing:1/4"OD .04W Blue Nylon		2.3 ft
	029956	Harness:PMX800 Power Unit		1
20	009480	Pot:250-Ohm 1W 10% 1T Cerm	P1	1
21	029962	Recept. SA:PMX800 Pwr Unit Quick Disc.		1
22	004532	Locknut:42/43 Quick Disc. Recept.		1
23	008606	Socket:MS Cont		7
24	015282	Female Elbow:1/8NPTX1/4Push in tube		1
25	075362	Flat Washer:1/2 .500 1.50 .125 Nylon		1

Notes: **Bold** part numbers and descriptions are subassemblies.
 Indented normal type items are components of subassemblies

All mounting hardware in power supply drawings shown for reference only.

POWER SUPPLY - 400V CE

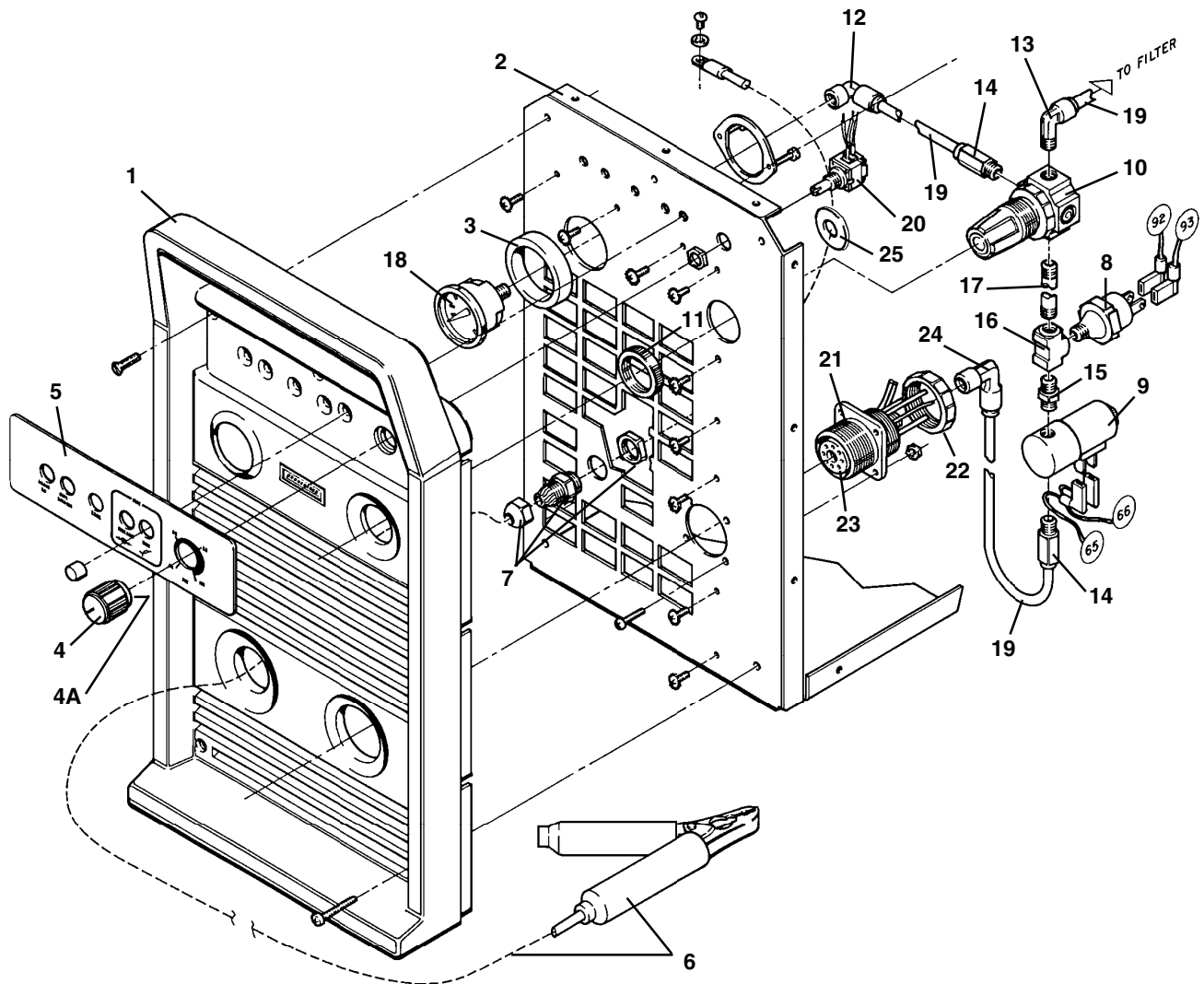

Figure 5-1 Powermax800 CE - Front

PARTS LIST - CE

POWER SUPPLY - 400V CE

Note: See **Section 4 Parts List** for parts and components of the non-CE Powermax800 systems.

Top and Right Side

Index No.	Part No.	Description	Ref. Desig.	Quantity
1	001521	Pnl:Powermax800 Pwr Unit Center		1
2	003078	Relay:30A NO Mag Blwt QDisc Term	CR2	1
	129046	Heatsink SA:Powermax800 CE Power Unit		1
3	004721	Heatsink:Powermax800 Pwr Unit		1
4	008947	Thermal Pad:AL-315-114		1
5	008905	Thermal Pad:AL-370-134		2
6	008906	Thermal Pad:AL-380-100		2
7	009849	Resistor:20-Ohm 50W 5% NON-IND		4
8	009850	Resistor:20-Ohm 25W 5% NON-IND		4
9	009918	Capacitor:.012µF 1000WV 10% Poly		4
9A	009968	Capacitor:6800pF 1000MV 10% Poly		4
10	005178	Temp. Switch Opens 85°/Closes 75°C	TS1	1
11	029998†	IGBT Gate Drive SA:Powermax800	Q1	1
12	029998†	IGBT Gate Drive SA:Powermax800	Q2	1
13	109018†	Diode:600V 100A UFast Recovery Dual	D2	1
14	109018†	Diode:600V 100A UFast Recovery Dual	D3	1
15	109043†	Diode:1600V 30A 3PH Bridge Isol Bplr	D1	1
16	041517	PCB Assy:Powermax800 Control		1
	008989	Fuse:500ma 250V IEC 127-3 Fast	F1-F4 (pcb fuse)	4
17	041532***	PCB Assy:Powermax800-ZB Power		1
18	014137	Current Sense Transformer, 40A	CS1	1
19	014137	Current Sense Transformer, 40A	CS2	1
20	008301	Fuse Holder:2P 30A 13/32 X 1-1/2		1
21	008752	Fuse Block:3P 30A 600V 13/32X1-1/2"		1
22	008958	Fuse:1A 500V 10mmX38mm Slo	F1, F2	2
23	008959	Fuse:20A 500V 10mmX38mm Slo		3
	029978*	Heatsink SA:Pwrmax800 PA Cont PCB	Q3	
24	004673*	Heatsink:Powermax800 PA Cont		
25	008905*	Thermal Pad:AL-370-134		
26	109020†*	Diode:600V 100A Fast IGBT Module		
27	041486*	PCB Assy:Pwrmax800 PA Cont		
	128036**	Kit:Powermax800 Machine Interface		
28	041494**	PCB Assy:Powermax800 Machine Interface		

Notes: **Bold** part numbers and descriptions are subassemblies.
 Indented normal type items are components of subassemblies.
 All mounting hardware in power supply drawings shown for reference only.

† Order corresponding thermal pads when ordering these items

* Available only on power supplies with the pilot arc control option

** Available only on power supplies with the machine interface option

*** For power supplies with serial numbers before 800-010000, order 128108 power board kit to replace power board.

POWER SUPPLY - 400V CE

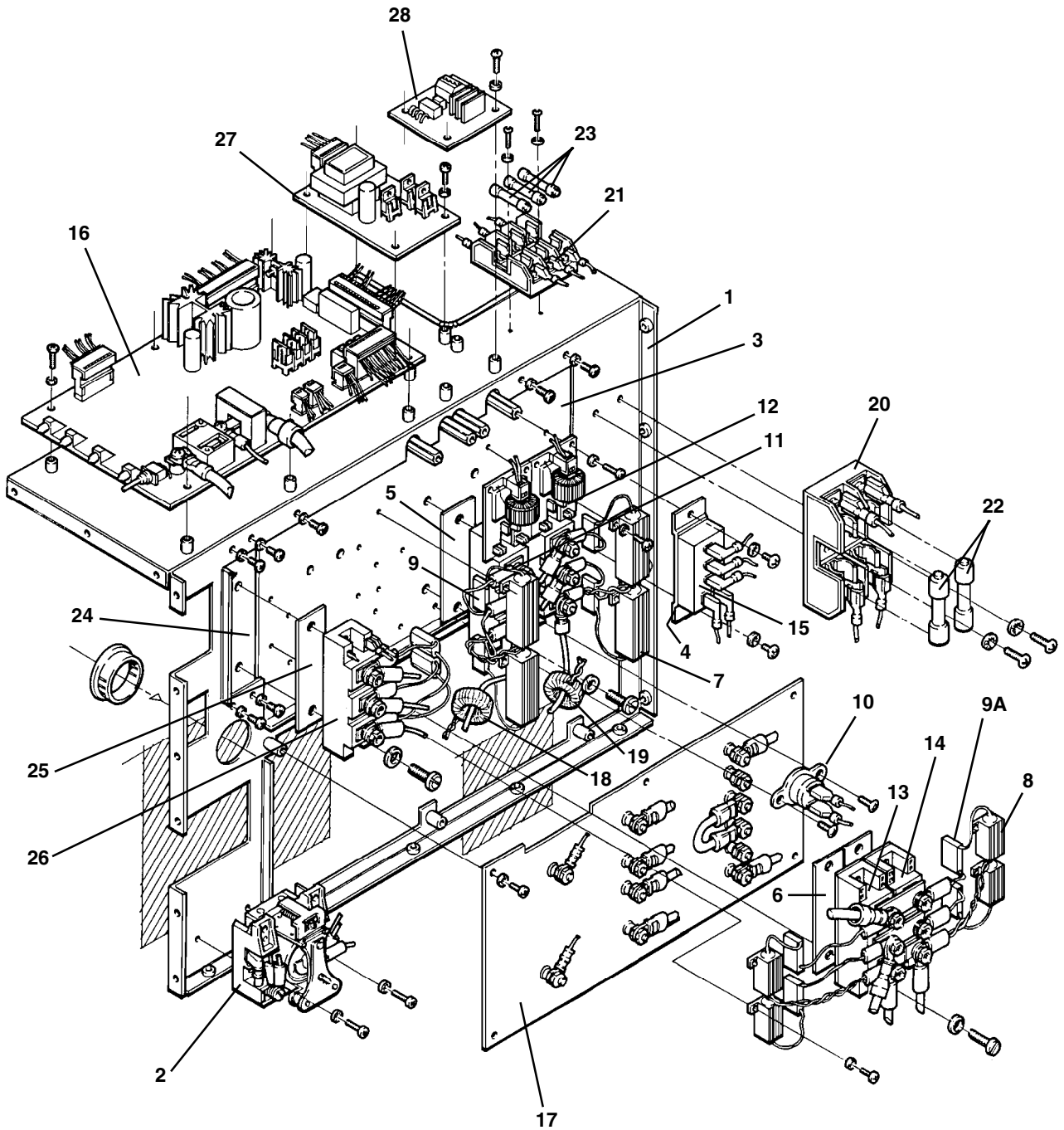

Figure 5-2 Powermax800 CE - Top and Right Side

PARTS LIST - CE

POWER SUPPLY - 400V CE

Note: See **Section 4 Parts List** for parts and components of the non-CE Powermax800 systems.

Bottom and Left Side

Index No.	Part No.	Description	Ref. Desig.	Quantity
1	001521	Panel:Powermax800 Pwr Unit Center		1
2	001522	Chassis:Powermax800 Pwr Unit		1
3	004667	Bracket:Powermax800 Pwr Unit Fan		1
4	014209	Xfmr:Powermax800 CE 400V Control	T1	1
5	014211	Xfmr:Powermax800 200-230-400 Power	T2 (w/TS2)	1
6	014186	Inductor:Powermax800 2MH 50A	L1	1
7	027443	Fan:260CDM 120VAC 50-60HZ	M1	1
	129046	Heatsink SA:Powermax800 CE Power Unit		1
8	004721	Heatsink:Powermax800 Power Unit		1
9	041532***	PCB Assy:Powermax800-ZB Power		1
	029978*	Heatsink SA:Pwrmax800 PA Cont PCB	Q3	
10	004673*	Heatsink:Powermax800 PA Cont		
11	028908**	Kit:Powermax800 Cooling Fan Filter		
12	129100	Capacitor SA:Powermax800-CE		1

Notes: **Bold** part numbers and descriptions are subassemblies.
Indented normal type items are components of subassemblies.

All mounting hardware in power supply drawings shown for reference only.

* Available only on power supplies with the pilot arc control option

** Available only as an option

*** For power supplies with serial numbers before 800-010000, order 128108 power board kit to replace power board.

POWER SUPPLY - 400V CE

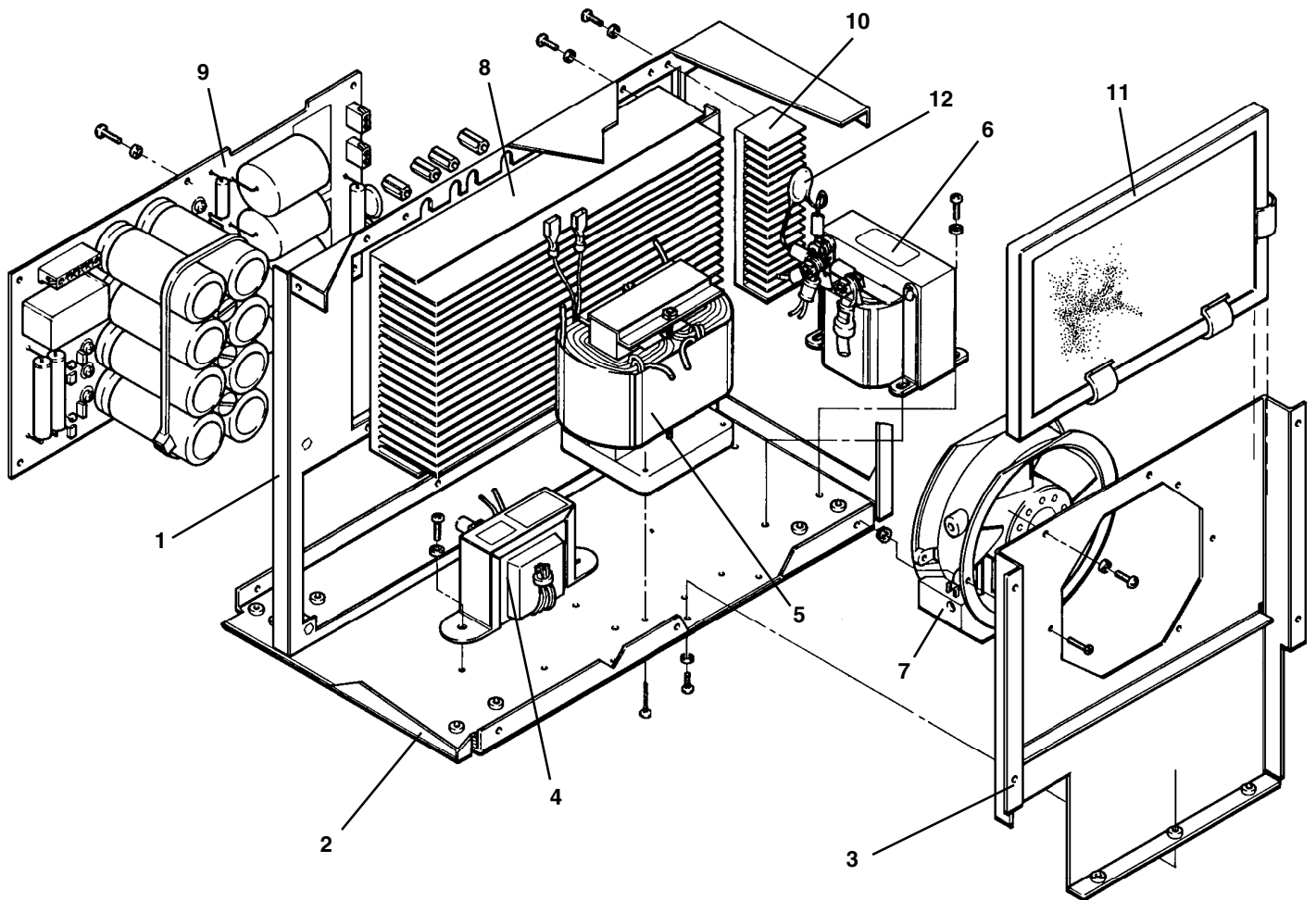

Figure 5-3 Powermax800 CE - Bottom and Left Side

PARTS LIST - CE

POWER SUPPLY - 400V CE

Note: See **Section 4 Parts List** for parts and components of the non-CE Powermax800 systems.

Rear

Index No.	Part No.	Description	Ref. Desig.	Quantity
1	001503	Pnl:Powermax800 Pwr Unit Plastic Rear		1
2	001522	Chassis:Powermax800 Pwr Unit		1
3	129068	Circuit Breaker SA:4Pole 480V W/TC	S1	1
4	129151	Contactactor SA:Powermax800	CR1	1
	029955	Manifold SA:Powermax800 Pwr Unit		1
5	011072	Filter:20 Micron 1/8FPT		1
6	015285	Male Connector:1/8NPTX1/4Push in Tube		1
7	011079	Filter Element for 011072 Filter		1
	129048	Linecord Panel SA:Powermax800 CE Pwr Unit		1
8	001571*	Panel:Powermax800 Power Cord & EMI		1
9	008782	Strain Relief:3/4NPT .375-.500		1
10	047180	Cord:2.5mm PVC HD21/22 7'3"		1
	129049	Electric Line Filter SA:Powermax800 CE		1
11	041505	PCB Assy:Powermax800-CE Line Filter		1
12	004692	Bracket:Powermax800-CE EMI		1
13	008949	Terminal Board: 3-Term		1
14	008279**	Strain Relief:PG9/5X.187-.312 Nylon		
15	123099**	Cable: Powermax800 Machine Interface		
	008201**	Receptacle Shell: 17-14 Reverse Sex		
	008186**	Socket:24-20 AWG Type III		

Notes: **Bold** part numbers and descriptions are subassemblies.
 Indented normal type items are components of subassemblies

All mounting hardware in power supply drawings shown for reference only.

* Use 129136 to replace power cord rear panel if you have the machine interface option.

** Available only with the machine interface option

POWER SUPPLY - 400V CE

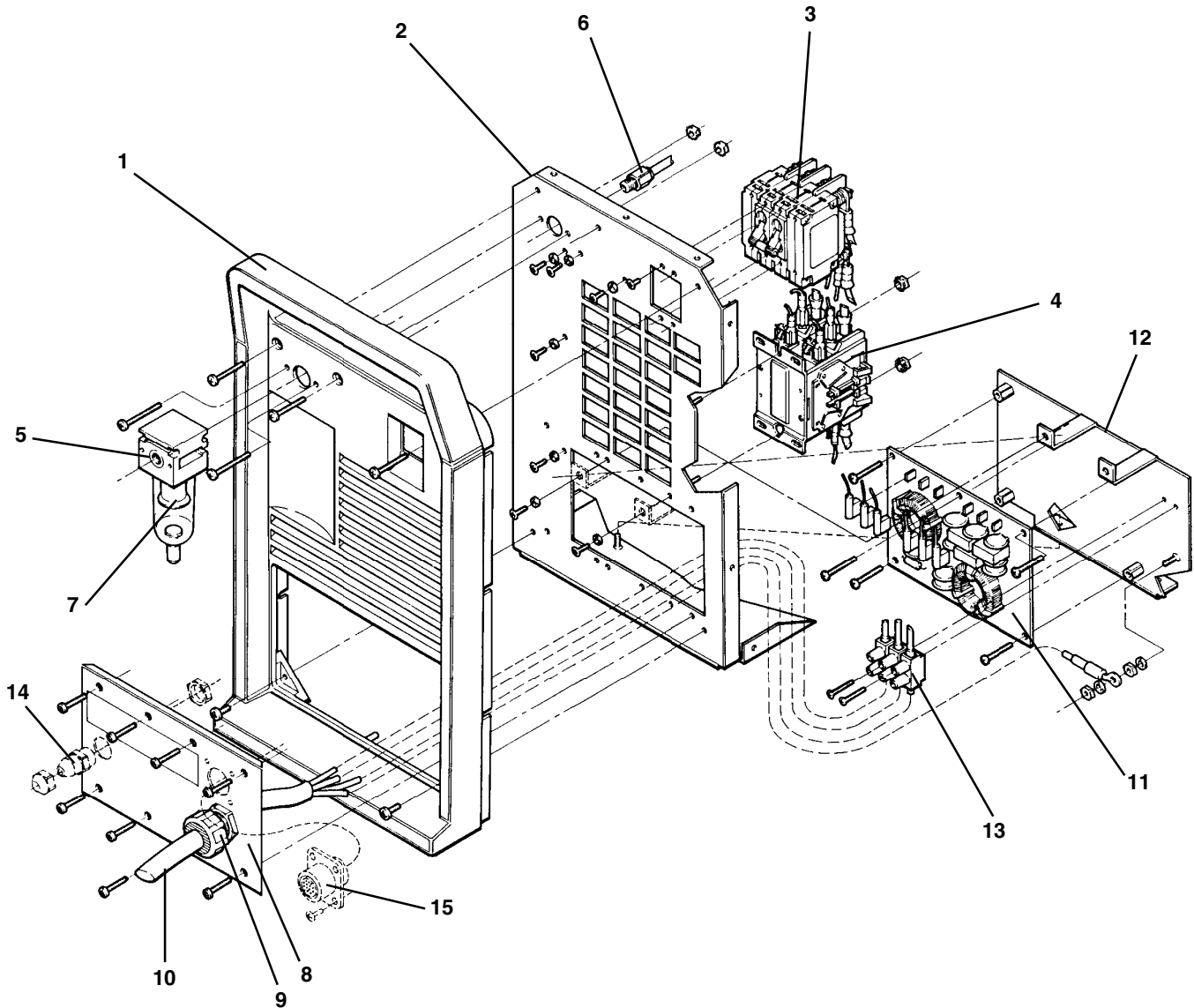

Figure 5-4 Powermax800 CE - Rear

PARTS LIST - CE

PAC121TS Torch Assembly and 25' (7.6 m) Lead - 083003 PAC121TS Torch Assembly and 50' (15.2 m) Lead - 083004

Part Number	Description
001288	Handle, PAC121T
002244	Safety Trigger, PAC121T
005094	Switch, Torch Pushbutton
020351	Electrode, Air
020361	Ring, Swirl
027254	Trigger Spring, PAC 121T
027466	Ring, Gutcha
075340	Screws, P/S, # 4 x 5/8, PH, RND, S/B
120282	Nozzle:PAC121 50A Shield
120283	Shield:PAC121 50A
120301	Cap, Retaining
120556	Torch Main Body w/Switch, PAC121T
044016	O-Ring:BUNA 90Duro .614X.070
129001*	Torch Lead, 25 ft. (7.6 m)
129002**	Torch Lead, 50 ft. (15.2 m)
044009	Quick Disconnect O-Ring (not shown)

* Used only in 083003

** Used only in 083004

Note: See page 5-12 for detail of consumable parts

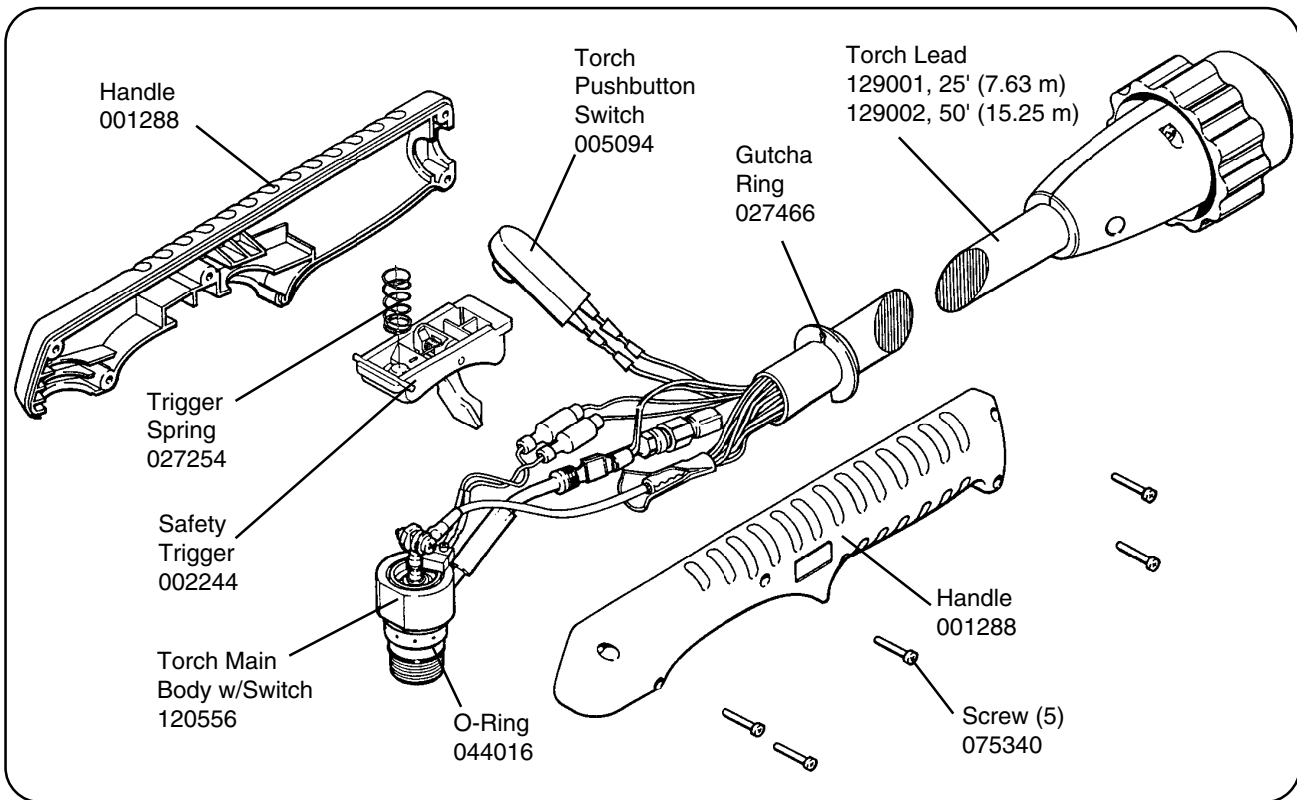

Figure 5-5 PAC121TS Torch Assembly and Leads

PARTS LIST - CE

PAC121MS Torch Assembly and 14 ft (4.3 m) Lead - 083049 w/pigtail, 083054 no pigtail
PAC121MS Torch Assembly and 25 ft (7.6 m) Lead - 083011 w/pigtail, 083056 no pigtail
PAC121MS Torch Assembly and 35 ft (10.6 m) Lead - 083044 w/pigtail, 083057 no pigtail
PAC121MS Torch Assembly and 50 ft (15.2 m) Lead - 083012 w/pigtail, 083058 no pigtail

Part Number	Description
020351	Electrode
020361	Ring, Swirl
020559	Sleeve, Machine Torch, PAC121M
020620	Sleeve, Torch Position, PAC121M
028923	Torch Lead w/pigtail, 14 ft (4.3 m)
028918	Torch Lead w/pigtail, 25 ft (7.6 m)
028926	Torch Lead w/pigtail, 35 ft (10.6 m)
028919	Torch Lead w/pigtail, 50 ft (15.2 m)
128123	Torch Lead, no pigtail, 14 ft (4.3 m)
128125	Torch Lead, no pigtail, 25 ft (7.6 m)
128126	Torch Lead, no pigtail, 35 ft (10.6 m)
128127	Torch Lead, no pigtail, 50 ft (15.2 m)
044009	Quick Disconnect O-Ring (not shown)
075321	Socket Cap, 4-40 X 1/2, HX, SS
075322	M/S, 4-40 X 1/4, SL, SZ
120282	Nozzle: PAC121 50A Shield
120326	Shield: PAC121M Machine Torch
120301	Cap, Retaining
120558	Torch Main Body w/ Switch, PAC121M
044016	O-Ring: BUNA 90 Duro .614X.070

Note: See page 5-12 for detail of consumable parts

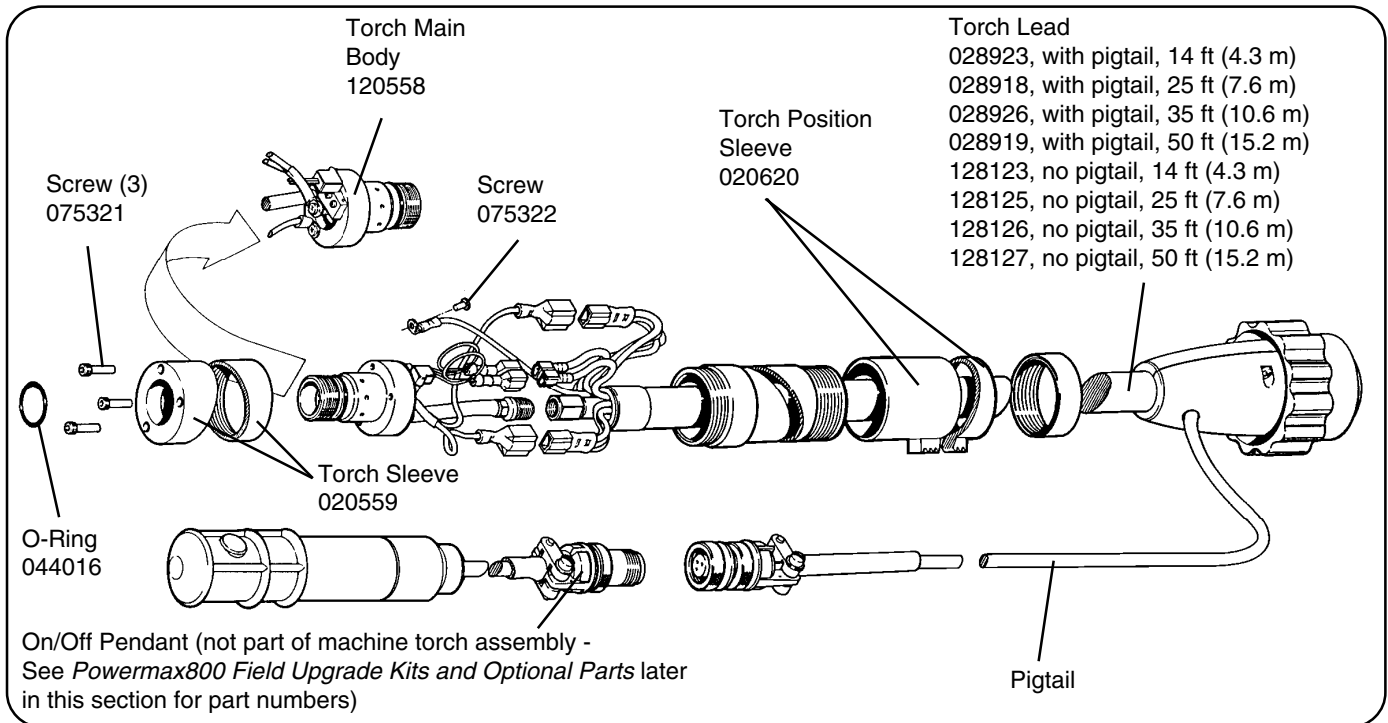

Figure 5-8 PAC121MS Torch Assembly and Leads

PARTS LIST - CE

CONSUMABLE PARTS - CE

Note: See **Section 4 Parts List** for parts and components of the non-CE Powermax800 systems.

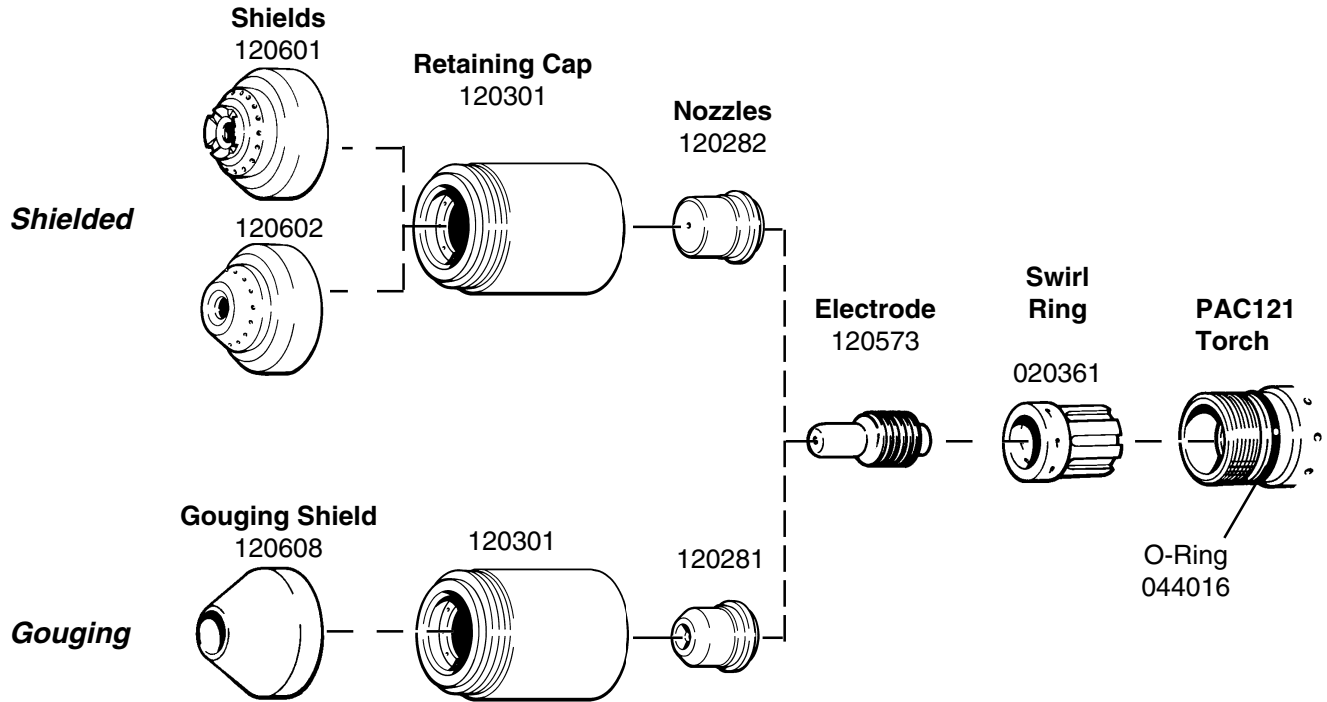

Figure 5-7 Consumable Parts - CE

Consumable Spare Parts Kit - CE (128033)	
Part Number	Description (Quantity)
001285	Box, Consumable Parts (1)
120573	Electrode (3)
020361	Swirl Ring (1)
120282	Nozzle, 50A, Shielded (3)
120281	Nozzle, 50A, Gouging (1)
120601	Shield, T torch, (1)
120602	Shield, M torch (1)
120608	Shield, Gouging (1)
044016	O-Ring (3)
015152	Nipple, 1/8 NPT,QDisc, Steel (1)
015570	Bushing, Reducer, 1/4 X 1/8, Brass (1)
015604	Reducer, 1/4 FPT X 1/8 NPT, Brass (1)
027055	Lubricant, Silicone 1/4 Oz Tube (1)

POWERMAX800 FIELD UPGRADE KITS AND OPTIONAL PARTS

Part Number	Description
028714	On/Off Pendant w/Lead, 25 ft. (7.6 m) (Also comes standard with most machine torch system configurations. See note below.)
128061	On/Off Pendant w/Lead, 50 ft. (15.2 m)
128062	On/Off Pendant w/Lead, 75 ft. (23 m)
028864	Kit: Powermax800 Pwr Unit Wheels
028898	Pilot Arc Controller Kit
128036	Machine Interface Kit, 400V CE
028907	Work Cable, 50' (15.2 m)
028908	Cooling Fan Filter Kit:Powermax800
011079	Gas Filter Element
129019	Jumper:Powermax800 Link Box
008958	Fuse:1A 500V 10mm X 38mm Slo (Used on 200/230/400V and 400V CE power supplies)
023206	Cable: Machine Interface, 25 ft (7.6 m) (Comes standard with machine torch system configurations and with machine interface kits.)

POWER SUPPLIES - 400V CE, 3 ϕ , 50 HZ

Part Number	For Torch Type	With Pilot Arc Control	With Machine Interface
083018	Hand	No	No
083021	Hand	Yes	No
083024	Machine	No	Yes
083027	Machine	Yes	Yes

Notes: Contact your distributor or call the nearest Hypertherm office for hand and machine torch system configurations.

See **Section 4 Parts List** for parts and components of non-CE Powermax800 systems.

PARTS LIST - CE

RECOMMENDED SPARE PARTS - POWERMAX800 400V CE

Part Number Reference	Description	Page
003078	Relay:30A NO Mag Blwt QDisc Term	5-5
129068	Circuit Breaker SA:4Pole 480V W/TC	5-9
129151	Contactora SA:Powermax800	5-9
008958	Fuse:1A 500V 10mm X 38mm GI Slo(2)	5-5
008959	Fuse:20A 500V 10mm X 38mm GI Slo(3)	5-5
014209	Xfmr:Powermax800 CE 400V Control	5-7
014211	Xfmr:Powermax800 200/230/400 Power	5-7
014186	Inductor:Powermax800 2MH 50A	5-7
023922	Cable w/Clamp:PMX800 Work 20'	5-3
027443	Fan:260CDM 120VAC 50-60HZ	5-7
005112	Pressure Switch:39 Psi .013 Orifice	5-3
006054	Sol. Valve:100# 1/8FPT 24VAC NC	5-3
011072	Filter:20 Micron 1/8FPT	5-9
011079	Filter Element for 011072 Filter	5-9
011073	Regulator:0-125 Psig 1/8FPT	5-3
022027	Press. Gauge:160# 1.5" 1/8CBM Panel	5-3
129046	Heatsink SA:Powermax800 CE Power Unit	5-5
109018/008906	Diode:600V 100A UFast Recovery Dual (2)/Thermal Pad:AL-380-100 (2)	5-5
109043/008947	Diode:1600V 30A 3PH Bridge/Thermal Pad:AL-315-114	5-5
005178	Temp. Switch Opens 85°/Closes 75°C	5-5
009849/008903	Resistor:20-Ohm 50W 5% NON-IND (4)/Thermal Pad:AL-197-114 (4)	5-5
009850/008902	Resistor:20-Ohm 25W 5% NON-IND (4)/Thermal Pad:AL-103-108 (4)	5-5
009918	Capacitor:.012UF 1000WV 10% Poly (4)	5-5
009968	Capacitor:6800pF 1000MV 10% Poly (4)	5-5
029998/008905	IGBT Gate Drive SA:Powermax800 (2)/Thermal Pad:AL-370-134 (2)	5-5
041517	PCB Assy:Powermax800 Control	5-5
041532	PCB Assy:Powermax800-ZB Power	5-5, 5-7
129049	Electric Line Filter SA:Powermax800-CE	5-9
047180	Cord:2.5mm PVC HD21/22, 7'3"	5-9
028908	Kit:Powermax800 Cooling Fan Filter	5-7

See **Section 4 Parts List** for parts and components of non-CE Powermax800 systems.

Section 6 WIRING DIAGRAMS

In this section:

Powermax800 Electrical Schematic: 208/240/480V	6-2
Powermax800 Electrical Schematic: 200/230/400V	6-3
Powermax800 Electrical Schematic: 400V–CE	6-4
Powermax800 Troubleshooting Schematic 1 of 2	6-5
Powermax800 Troubleshooting Schematic 2 of 2	6-6
Powermax800 CE Troubleshooting Schematic 1 of 2	6-7
Powermax800 CE Troubleshooting Schematic 2 of 2	6-8

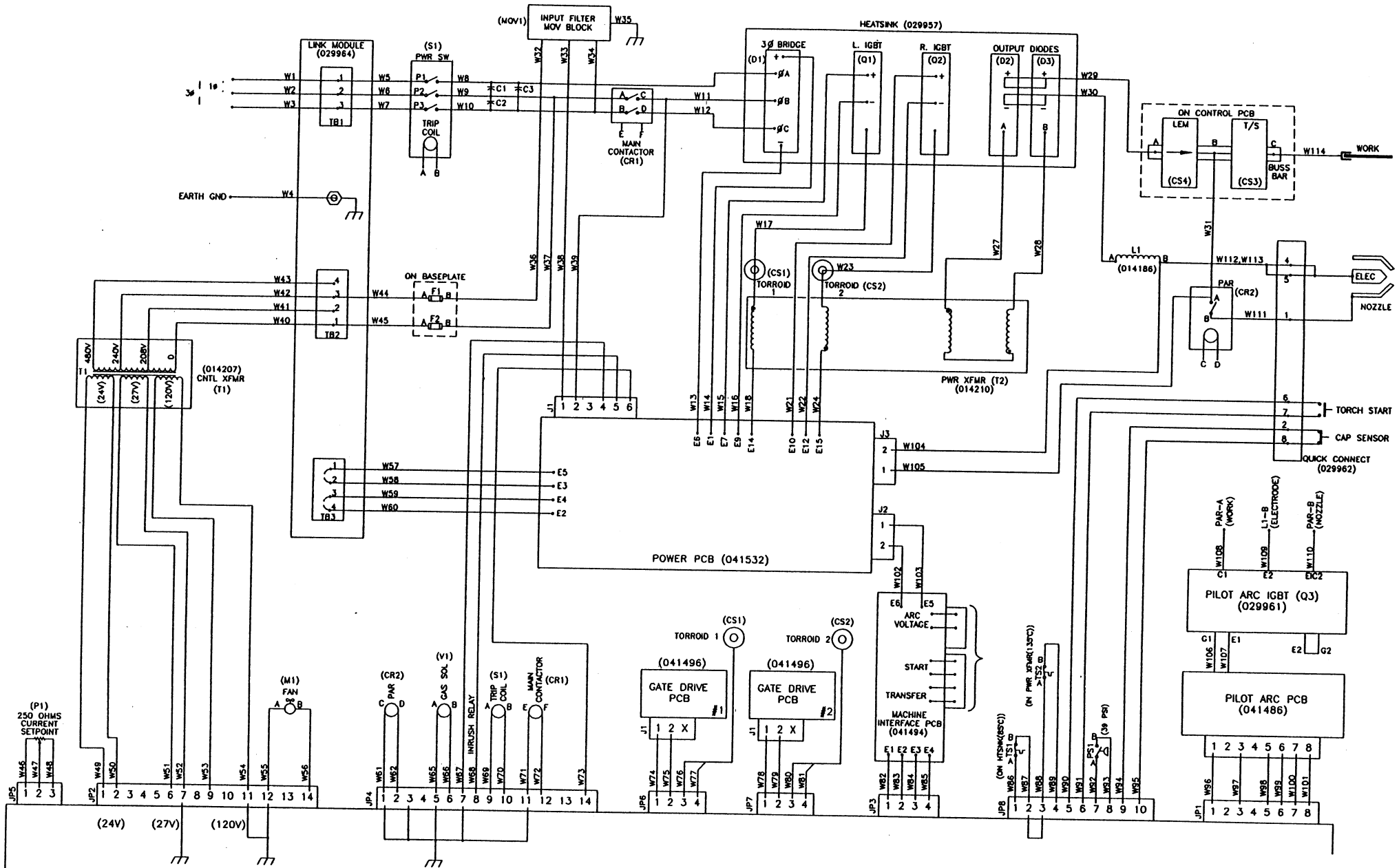

6-2

CONTROL PCB (041472)

PMX800 ELEC SCH: 208-240-480V
 013-3-285
 1 OF 1



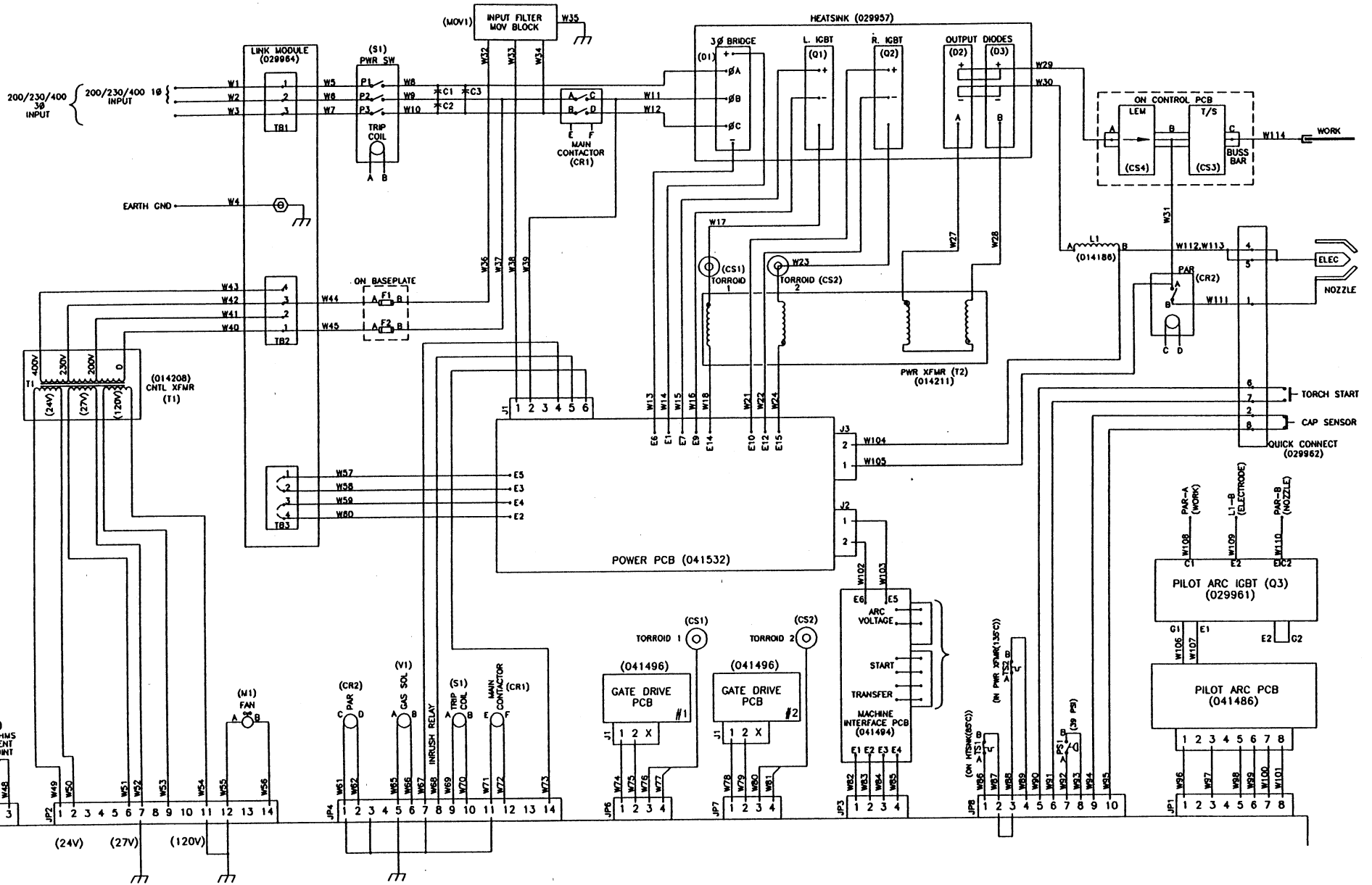

C-3

CONTROL PCB (041517)

PMX800 ELEC SCH: 200-230-400V
 013-3-291
 1 OF 1



NOT USED:
W35, W41, W42, W44, W45

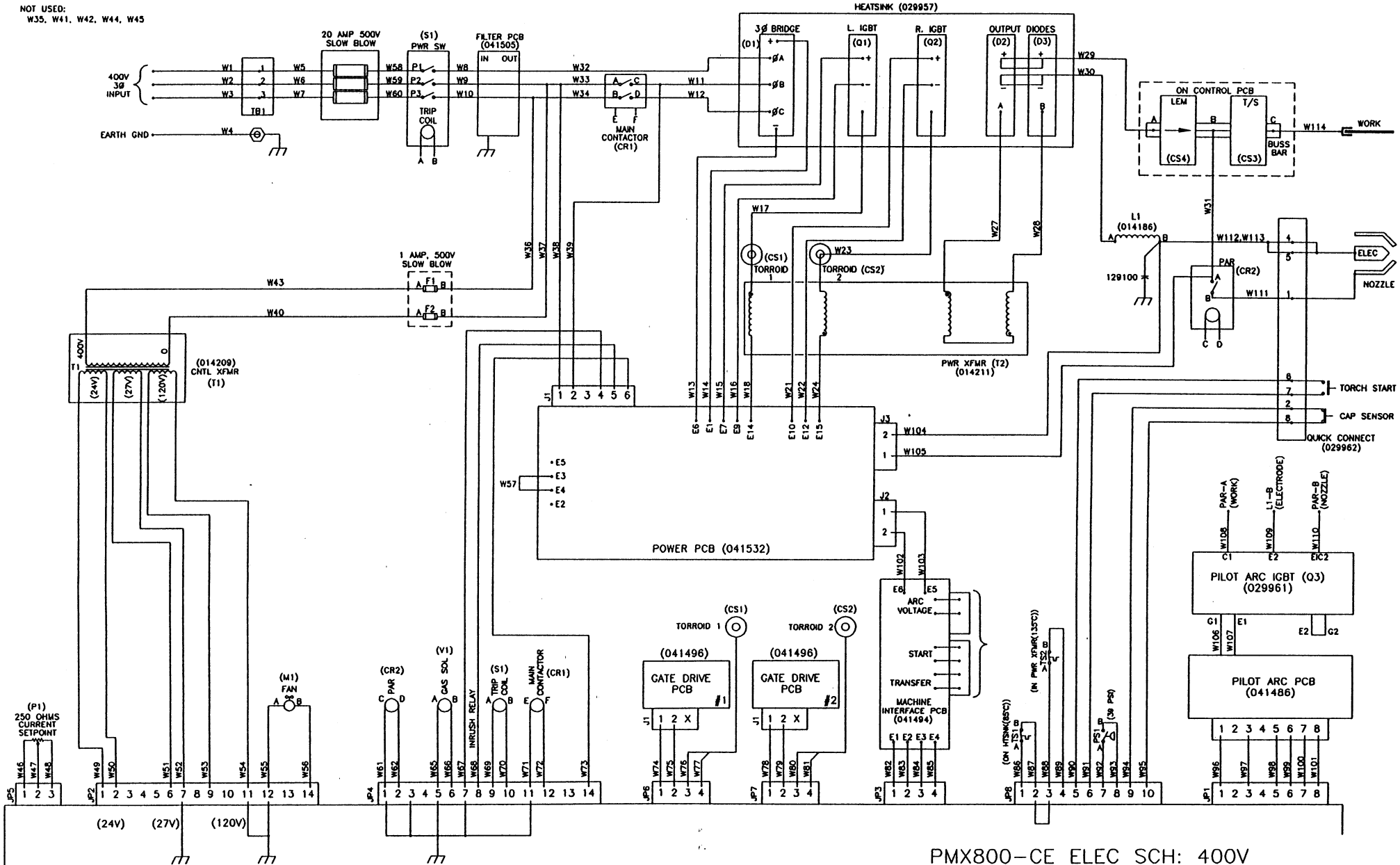

6-4

CONTROL PCB (041517)

PMX800-CE ELEC SCH: 400V

013-3-290

1 OF 1



Control Board Test Points

Test Point	Description	Value
TP1	Transfer signal.	A logic high (12V) indicates that the arc is transferred.
TP2	Start signal.	A logic high (12V) indicates that the torch start switch is on.
TP3	GND.	
TP4		+12V
TP5	Unregulated DC voltage.	Approximately 30VDC at nominal input voltage.
TP6		±18V
TP7	INV-ON signal.	A logic high (12V) indicates that the inverter is on.
TP8	Transfer latch signal.	A logic high (12V) indicates that unit is in transferred mode.
TP9	Temp OK signal.	A logic high (12V) indicates that all temperatures are OK.
TP10	Continuous PA threshold voltage.	Set to 3.55V by P3.
TP11		7.0V
TP15	Error amplifier reference voltage.	During inverter operation this signal is 1.915V at 50A current setting and .75V at 20A current setting.
TP16	Error amplifier output voltage	
TP17	Reference voltage	2.50V
TP18	Output current value signal	38.3mv/amp
TP19	Wiper voltage.	2.5V at 50A current setting and 1.00V at 20A current setting.
TP20	GND	
TP21	Buffered, inverted, capacitor lead version of pulse width modulator B signal.	
TP22	Buffered, inverted version of pulse width modulator A signal.	
Fuses		
F1, F2	Cap sensor circuit protection	.5A (see Parts List for part number and specifications)
F3, F4	Start circuit protection	.5A (see Parts List for part number and specifications)

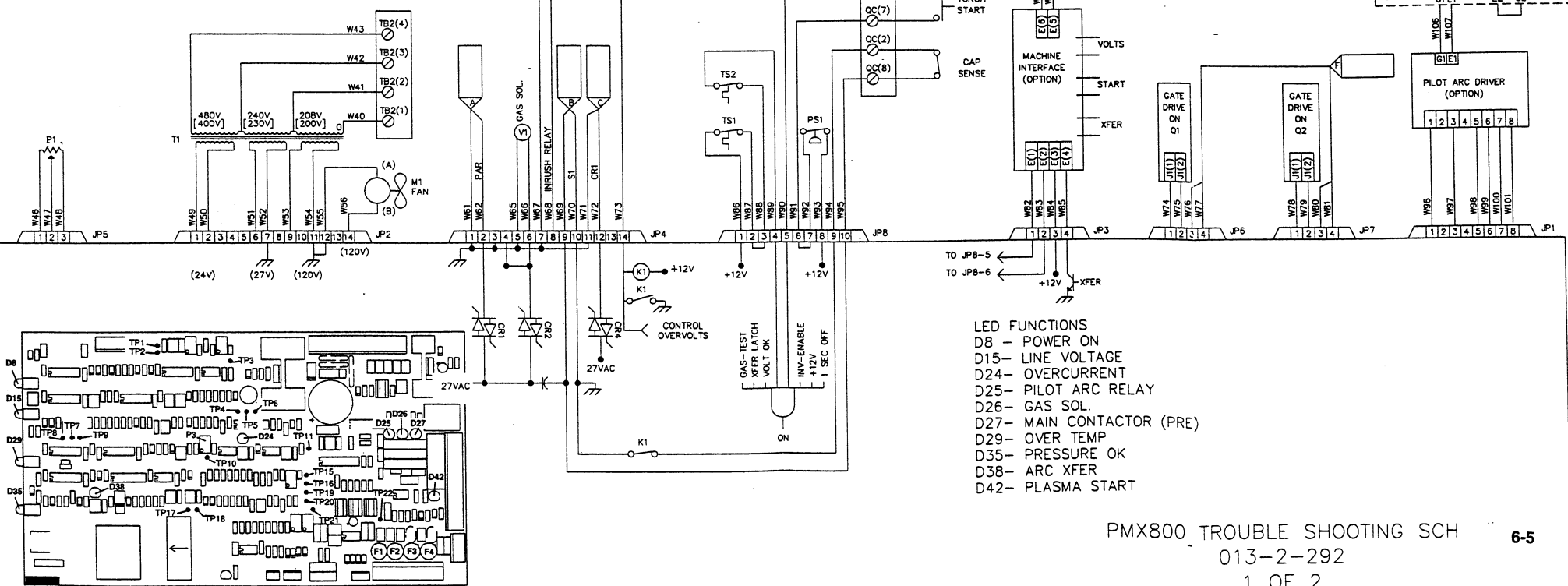

- LED FUNCTIONS
- D8 - POWER ON
 - D15- LINE VOLTAGE
 - D24- OVERCURRENT
 - D25- PILOT ARC RELAY
 - D26- GAS SOL.
 - D27- MAIN CONTACTOR (PRE)
 - D29- OVER TEMP
 - D35- PRESSURE OK
 - D38- ARC XFER
 - D42- PLASMA START

Power Board Test Points

Test Point	Description	Value
E1 to E3	High-voltage power - Left Inverter	+300VDC
E4 to E3	One-half of High-voltage power - Left Inverter	+150VDC
E4 to E5	High-voltage power - Right Inverter	+300VDC
E15 to E5	One-half of High-voltage power - Right Inverter	+150VDC
J1-5 to J1-4	"Soft start" signal from control PCB. After incoming voltage is accepted by control board, control board sends +12VDC to relay RL1 on power board. LINE VOLTAGE LED will remain lit until "soft start" signal is complete (about 5 seconds after S1 is thrown).	+12VDC 5 sec. after throwing power switch S1.
J1-6 to J1-4	Shut down signal from power board. Protection circuit on power board will go low (= 0 VDC) to control board to shut down power supply if it detects over voltage.	+12 VDC normally. = 0 VDC if voltage too high.



WARNING



SHOCK HAZARD: The "E" terminals and J1 are accessible from the back side of the power PCB. Use extreme caution when taking these readings. Voltages up to 300 VDC are present at the rear of the power PCB.

The large electrolytic capacitors, (blue-cased cylinders) located on the front side of the power PC board store large amounts of energy in the form of electrical voltage. Even if the power is off, dangerous voltages exist at the capacitor terminals on the PC board and on certain areas of the PC board. Never discharge the capacitors with a screwdriver or other implement... explosion, property damage and/or personal injury will result.

Wait at least 5 minutes after turning the power supply off before handling the PC board or capacitors. If questions or problems arise during servicing, call Hypertherm Technical Services at 1-800-643-9878.

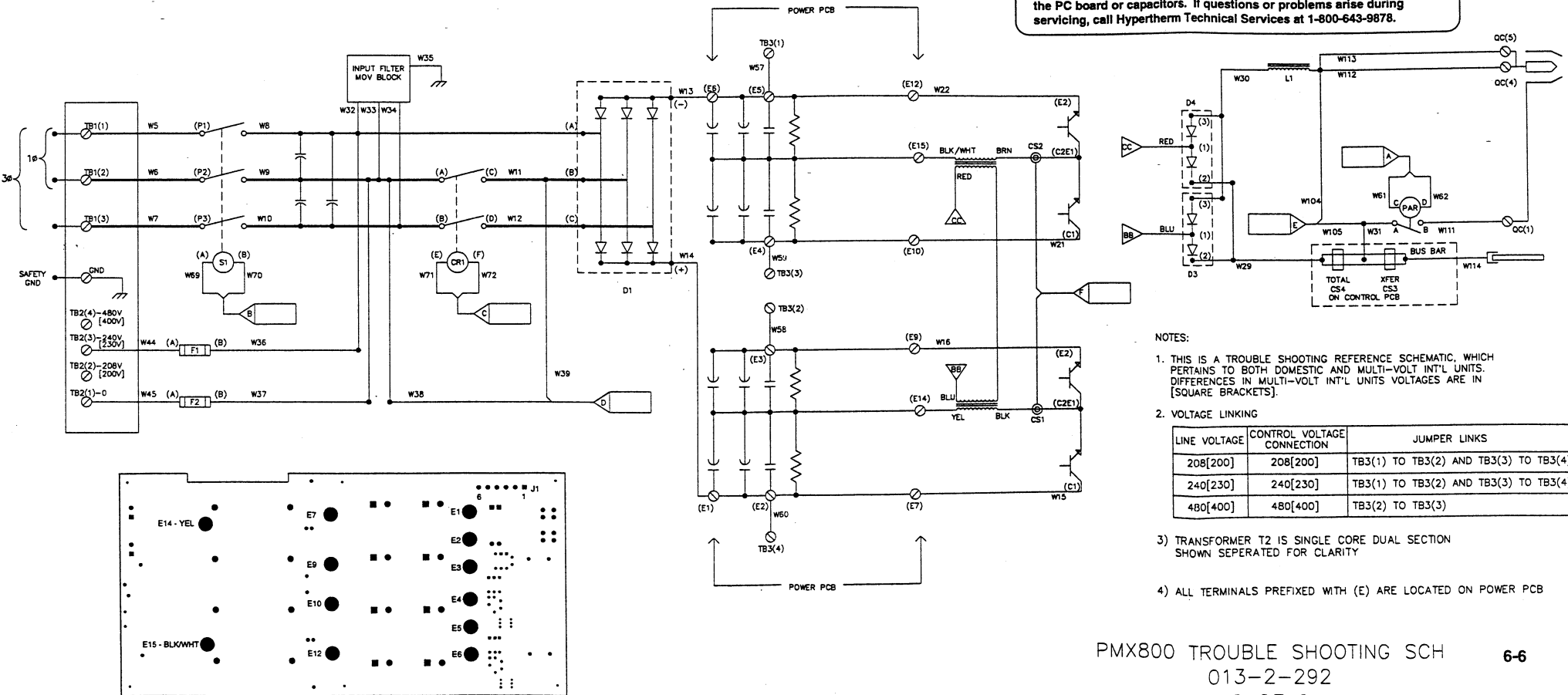

- NOTES:
- THIS IS A TROUBLE SHOOTING REFERENCE SCHEMATIC, WHICH PERTAINS TO BOTH DOMESTIC AND MULTI-VOLT INT'L UNITS. DIFFERENCES IN MULTI-VOLT INT'L UNITS VOLTAGES ARE IN [SQUARE BRACKETS].
 - VOLTAGE LINKING

LINE VOLTAGE	CONTROL VOLTAGE CONNECTION	JUMPER LINKS
208[200]	208[200]	TB3(1) TO TB3(2) AND TB3(3) TO TB3(4)
240[230]	240[230]	TB3(1) TO TB3(2) AND TB3(3) TO TB3(4)
480[400]	480[400]	TB3(2) TO TB3(3)
 - TRANSFORMER T2 IS SINGLE CORE DUAL SECTION SHOWN SEPERATED FOR CLARITY
 - ALL TERMINALS PREFIXED WITH (E) ARE LOCATED ON POWER PCB

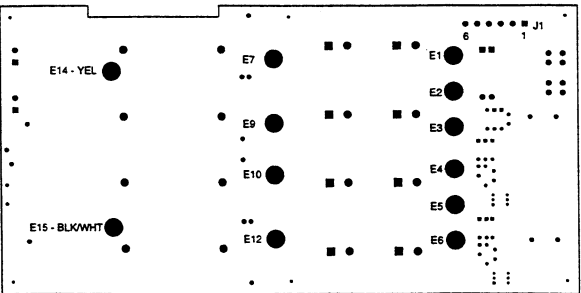

Control Board Test Points

Test Point	Description	Value
TP1	Transfer signal.	A logic high (12V) indicates that the arc is transferred.
TP2	Start signal.	A logic high (12V) indicates that the torch start switch is on.
TP3	GND	
TP4		+12V
TP5	Unregulated DC voltage.	Approximately 30VDC at nominal input voltage.
TP6		+18V
TP7	INV-ON signal.	A logic high (12V) indicates that the inverter is on.
TP8	Transfer latch signal.	A logic high (12V) indicates that unit is in transferred mode.
TP9	Temp OK signal.	A logic high (12V) indicates that all temperatures are OK.
TP10	Continuous PA threshold voltage.	Set to 3.55V by P3.
TP11		7.0V
TP15	Error amplifier reference voltage.	During inverter operation this signal is 1.915V at 50A current setting and .75V at 20A current setting.
TP16	Error amplifier output voltage	
TP17	Reference voltage	2.50V
TP18	Output current value signal	38.3mV/amp
TP19	Wiper voltage.	2.5V at 50A current setting and 1.00V at 20A current setting
TP20	GND	
TP21	Buffered, inverted, capacitor feed version of pulse width modulator B signal.	
TP22	Buffered, inverted version of pulse width modulator A signal.	
Fuses		
F1,F2	Cap sensor circuit protection	.5A (see Parts List for part number and specifications)
F3,F4	Start circuit protection	.5A (see Parts List for part number and specifications)

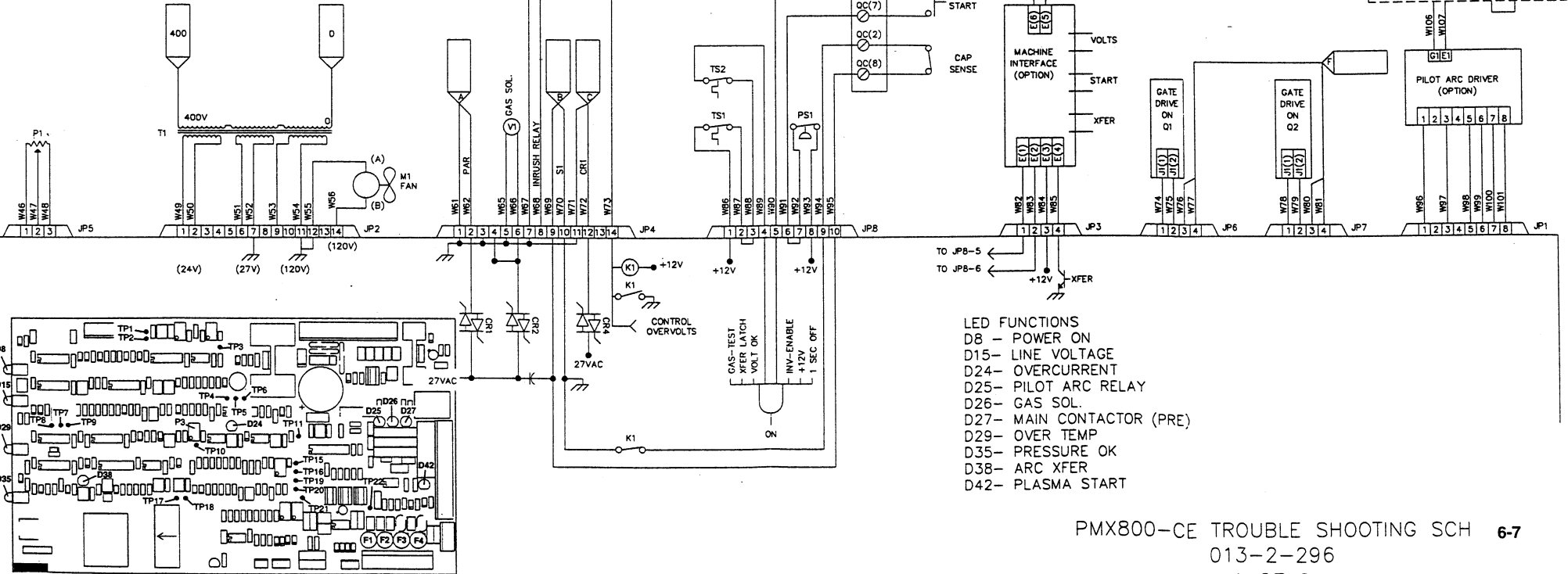

- LED FUNCTIONS
- D8 - POWER ON
 - D15 - LINE VOLTAGE
 - D24 - OVERCURRENT
 - D25 - PILOT ARC RELAY
 - D26 - GAS SOL
 - D27 - MAIN CONTACTOR (PRE)
 - D29 - OVER TEMP
 - D35 - PRESSURE OK
 - D38 - ARC XFER
 - D42 - PLASMA START

Power Board Test Points

Test Point	Description	Value
E1 to E3	High-voltage power - Left Inverter	+300VDC
E14 to E3	One-half of High-voltage power - Left Inverter	+150VDC
E4 to E5	High-voltage power - Right Inverter	+300VDC
E15 to E5	One-half of High-voltage power - Right Inverter	+150VDC
J1-5 to J1-4	"Soft start" signal from control PCB. After incoming voltage is accepted by control board, control board sends +12VDC to relay RL1 on power board. LINE VOLTAGE LED will remain lit until "soft start" signal is complete (about 5 seconds after S1 is thrown).	+12VDC 5 sec. after throwing power switch S1.
J1-6 to J1-4	Shut down signal from power board. Protection circuit on power board will go low (= 0 VDC) to control board to shut down power supply if it detects over voltage.	+12 VDC normally. = 0 VDC if voltage too high.



WARNING



SHOCK HAZARD: The "E" terminals and J1 are accessible from the back side of the power PCB. Use extreme caution when taking these readings. Voltages up to 300 VDC are present at the rear of the power PCB.

The large electrolytic capacitors, (blue-cased cylinders) located on the front side of the power PC board store large amounts of energy in the form of electrical voltage. Even if the power is off, dangerous voltages exist at the capacitor terminals on the PC board and on certain areas of the PC board. Never discharge the capacitors with a screwdriver or other implement... explosion, property damage and/or personal injury will result.

Wait at least 5 minutes after turning the power supply off before handling the PC board or capacitors. If questions or problems arise during servicing, call Hypertherm Technical Services at 1-800-643-9878.

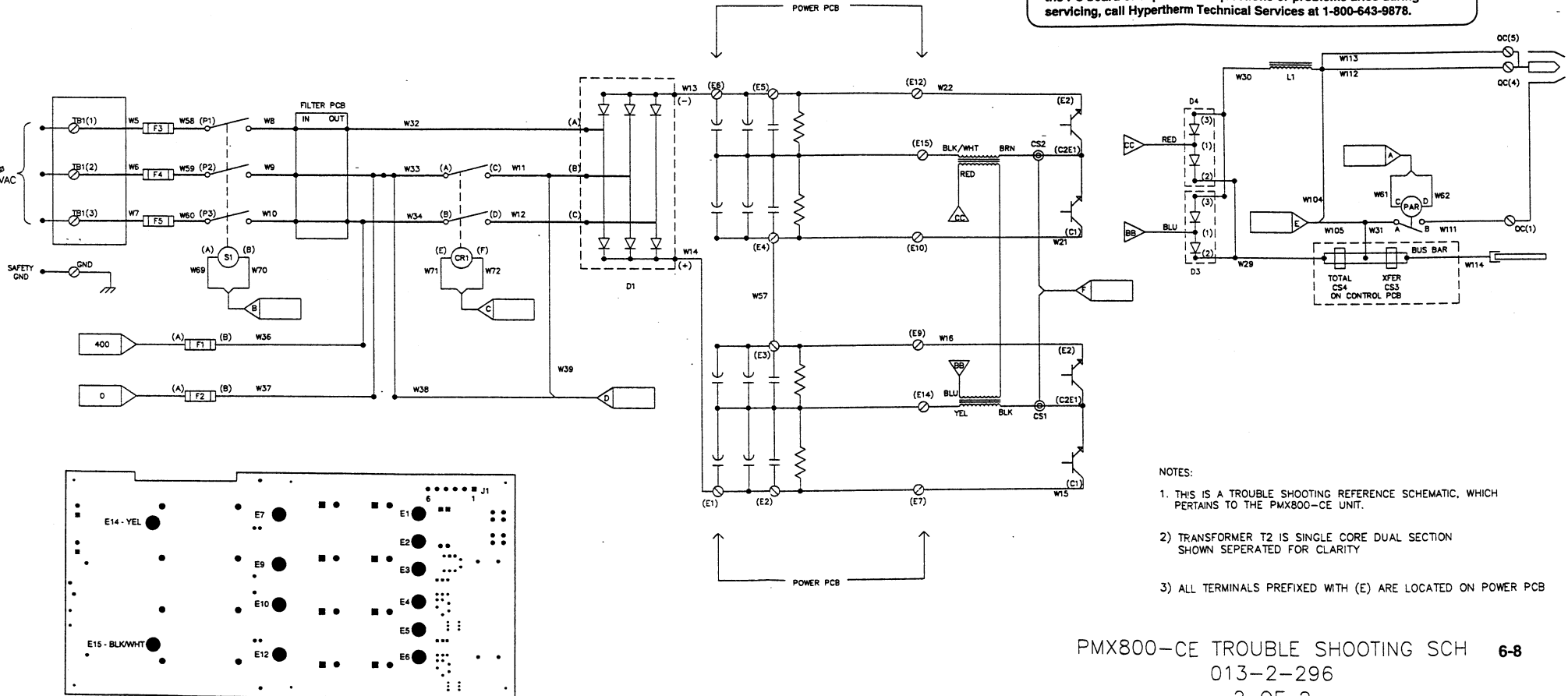

- NOTES:
- 1) THIS IS A TROUBLE SHOOTING REFERENCE SCHEMATIC, WHICH PERTAINS TO THE PMX800-CE UNIT.
 - 2) TRANSFORMER T2 IS SINGLE CORE DUAL SECTION SHOWN SEPERATED FOR CLARITY
 - 3) ALL TERMINALS PREFIXED WITH (E) ARE LOCATED ON POWER PCB

AERATION MANIFOLD FOR PLASMA CUTTING ALUMINUM

Introduction

When plasma arc cutting aluminum at the water table surface or below water, free hydrogen gas may be generated by the cutting process. The high temperature of the plasma process causes disassociation of oxygen and hydrogen from the water in the water table. The hot aluminum, which has a high affinity for oxygen, then combines with the oxygen leaving free hydrogen.

An effective means of avoiding free hydrogen buildup is to install an aeration manifold on the floor of the water table to replenish the oxygen content of the water.

Making an Aeration Manifold - Figure c-1

Make an **Aeration Manifold** with two-inch (50 mm) PVC tubing with one-inch (25 mm) **Distribution Lines** connected to it. Drill 1/8 inch (3 mm) holes every six inches (150 mm) in the distribution lines. Cap the ends of the distribution lines and install the lines so that oxygen is delivered to all parts of the cutting area.

Connect the manifold to a shop air line. Set a pressure regulator to obtain a steady stream of bubbles.

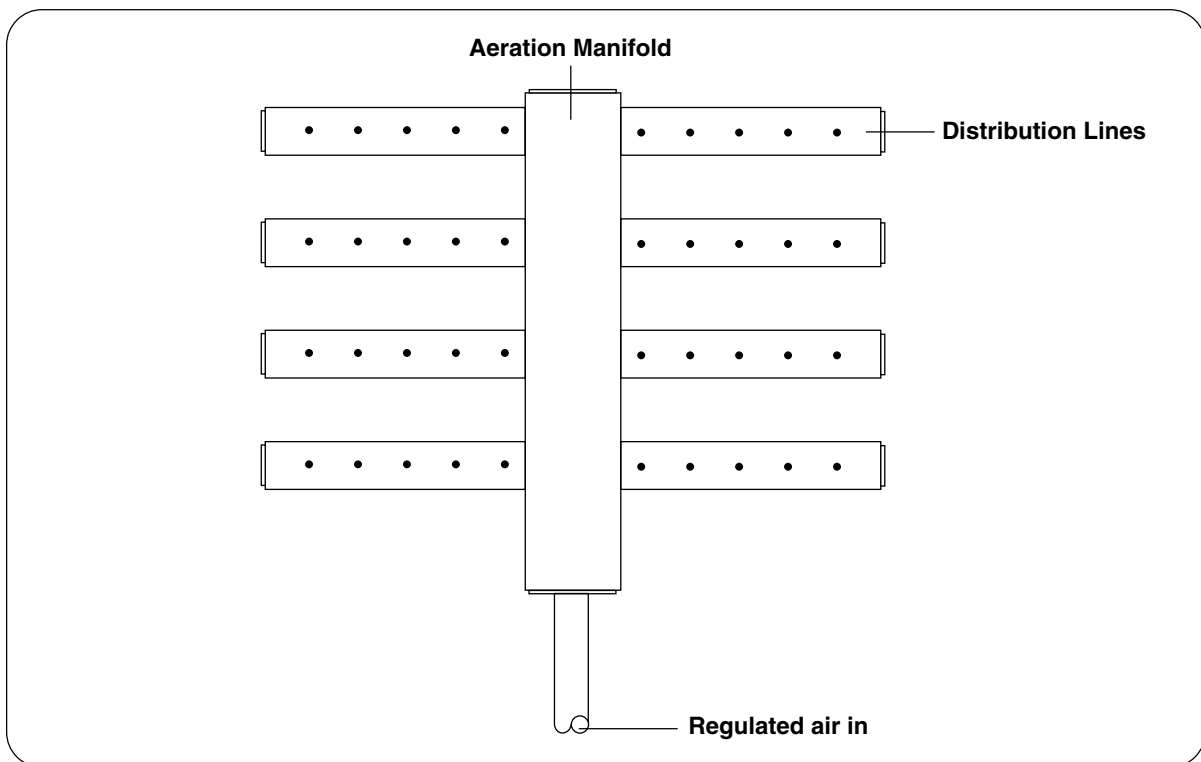

Figure a-1 Aeration Manifold

APPENDIX B

STANDARDS INDEX

For further information concerning safety practices to be exercised with plasma arc cutting equipment, please refer to the following publications:

1. ANSI Standard Z49.1, *Safety in Welding and Cutting*, obtainable from the American Welding Society, 550 LeJeune Road, P.O. Box 351020, Miami, FL 33135.
2. NIOSH, *Safety and Health in Arc Welding and Gas Welding and Cutting*, obtainable from the Superintendent of Documents, U.S. Government Printing Office, Washington, D.C. 20402.
3. OSHA, *Safety and Health Standards*, 29FR 1910, obtainable from the U.S. Government Printing Office, Washington, D.C. 20402.
4. ANSI Standard Z87.1, *Safe Practices for Occupation and Educational Eye and Face Protection*, obtainable from the American National Standards Institute, 1430 Broadway, New York, NY 10018.
5. ANSI Standard Z41.1, *Standard for Men's Safety-Toe Footwear*, obtainable from the American National Standards Institute, 1430 Broadway, New York, NY 10018.
6. ANSI Standard Z49.2, *Fire Prevention in the Use of Cutting and Welding Processes*, obtainable from the American National Standards Institute, 1430 Broadway, New York, NY 10018.
7. AWS Standard A6.0, *Welding and Cutting Containers Which Have Held Combustibles*, obtainable from the American Welding Society, 550 LeJeune Road, P.O. Box 351040, Miami, FL 33135.
8. NFPA Standard 51, *Oxygen — Fuel Gas Systems for Welding and Cutting*, obtainable from the National Fire Protection Association, 470 Atlantic Avenue, Boston, MA 02210.
9. NFPA Standard 70-1978, *National Electrical Code*, obtainable from the National Fire Protection Association, 470 Atlantic Avenue, Boston, MA 02210.
10. NFPA Standard 51B, *Cutting and Welding Processes*, obtainable from the National Fire Protection Association, 470 Atlantic Avenue, Boston, MA 02210.
11. CGA Pamphlet P-1, *Safe Handling of Compressed Gases in Cylinders*, obtainable from the Compressed Gas Association, 1235 Jefferson Davis Highway, Arlington, VA 22202.
12. CSA Standard W117.2, *Code for Safety in Welding and Cutting*, obtainable from the Canadian Standards Association Standard Sales, 178 Rexdale Boulevard, Rexdale, Ontario M9W 1R3, Canada.
13. NWSA booklet, *Welding Safety Bibliography*, obtainable from the National Welding Supply Association, 1900 Arch Street, Philadelphia, PA 19103.
14. American Welding Society Standard AWS F4.1, *Recommended Safe Practices for the Preparation for Welding and Cutting of Containers and Piping That Have Held Hazardous Substances*, obtainable from the American Welding Society, 550 LeJeune Road, P.O. Box 351040, Miami, FL 33135.
15. ANSI Standard Z88.2, *Practices for Respiratory Protection*, obtainable from the American National Standards Institute, 1430 Broadway, New York, NY 10018.
16. Canadian Electrical Code Part 1, *Safety Standards for Electrical Installations*, obtainable from the Canadian Standards Association, 178 Rexdale Boulevard, Rexdale, Ontario, Canada M9W1R3.